

# WOODFOLD



## DOOR INSTALLATION DOOR SERIES: 3300

BULLETIN INSTALL-3300-120423



**Read and understand these instructions before proceeding!**

**It saves frustration!**



**Beginning installation before checking things out is discouraged!**

***Measure Twice - Cut Once*** so to speak

### 1 PREPARATION

#### Preliminary Examination

Inspect the packaging. If the package was damaged when it arrived, contact the shipping carrier first, then notify Woodfold.

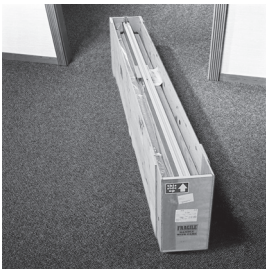

Confirm the match of the packaged door to the intended opening. The example label to the right shows the location of the critical information.

Lay out the contents on a flat surface near the opening where the door is to be installed.

The package(s) contents should include

- Door
- Track Section(s)
- Interlocking Jamb Molding (Aluminum extrusion a little less than the height of the door. See Page 5 for description.)
- Hardware packet (Screws etc.)
- These instructions (Yes, yes, we know you had to find them if you're reading them, but we like to be complete.)
- A copy of the shipping label and packing list with all the information you need if you have to call Woodfold for any reason. Hold on to it for future reference.

### Example Label

Your label will look similar but have your unique information

Opening Width: 14-6

Opening Height: 9-0

Right/Left Hand Stack: RH

Single/Double End: DE

Latch Style: TT 2 Sides Closet

Door Series: 3300V

Order Number: 11-06-0047

Number and Length of Track Pieces: 1 @ 120

Product Details: UPS, 1/2 Pair+, Bronze Hdw, Srt'd Sweepstrip, Sand. Geon O.O Fl. Cl., SI Jamb, BB Whls No, None, Track In 2nd Box 2011-06-16, CARB Compliant Thin MDF P1 93120



**Caution!** The factory greased the track for smooth operation! Hands and tools can spread the grease all over, so please be careful.

## Door Stacking: Double Ended (DE), Single Ended (SE), or Pair

For the purpose of these instructions, doors come in three basic configurations: Double Ended (DE), Single ended (SE) or a Pair. DE doors have Lead Posts at each end of the Panel set. SE doors have a Lead Post on one end and a Mounting system on the other end. Pairs are a set of SE that meet in the middle.

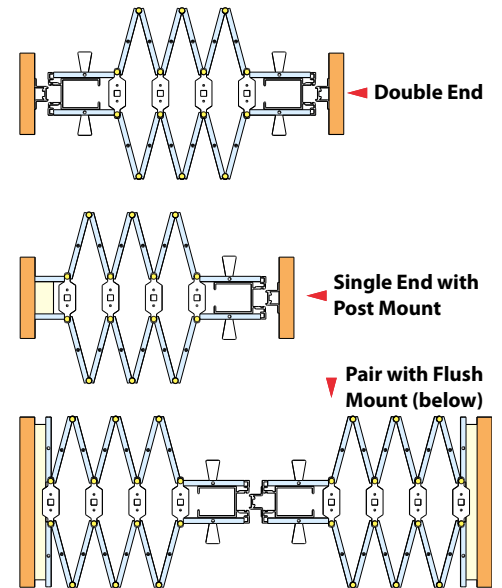

The next few steps are much easier if you have assistance

## 2 TRACK INSTALLATION

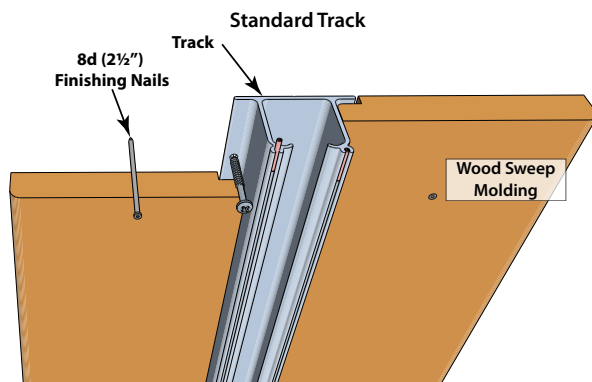

OR

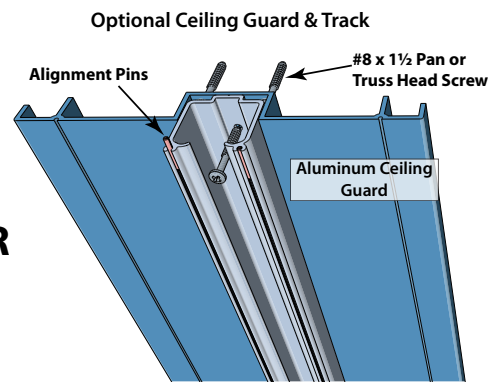

Verify that the track length is correct.

Dry fit the track in the opening. The correct length will just fit. If needed, trim the track with a hacksaw. Try to keep the metal filings from mixing with grease inside the track.

If the track is too short by more than 1/2", contact your dealer or Woodfold.



Need for alignment pins depends on the number of track sections. Short tracks with a single section will not have alignment pins.

**Note:** Some Pairs may have two track sections that butt together without alignment pins. Not to worry! It's OK

Insert the alignment pins into the groove of the track at the end that will mate to the next section. The split in the pin **MUST BE AWAY** (perpendicular, see illustration) from the slot in the track. Drive the spring pins completely into one track using a hammer

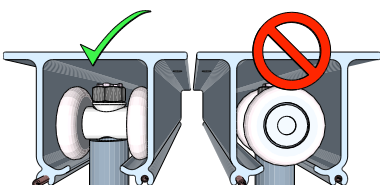
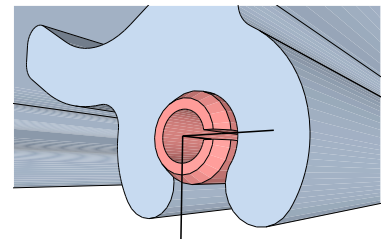

Thread the track onto wheels; lineup the wheels properly in the track grooves. Be careful not to insert the wheels sideways. You won't like the result.





**Important: Power Screw Drivers:** Check the length of your #2 Phillips Bit. It needs to extend at least 1¼" past the chuck. Any shorter and the chuck may tear up the track or the screw won't seat. It falls into the frustrating category when you have to order a new track.

Confirm the proper orientation of the door. See the door stacking illustrations at the top of Page 2. Position the track to ensure: it can be securely attached to the header and the Mounting system can be securely attached to the wall or doorjamb.

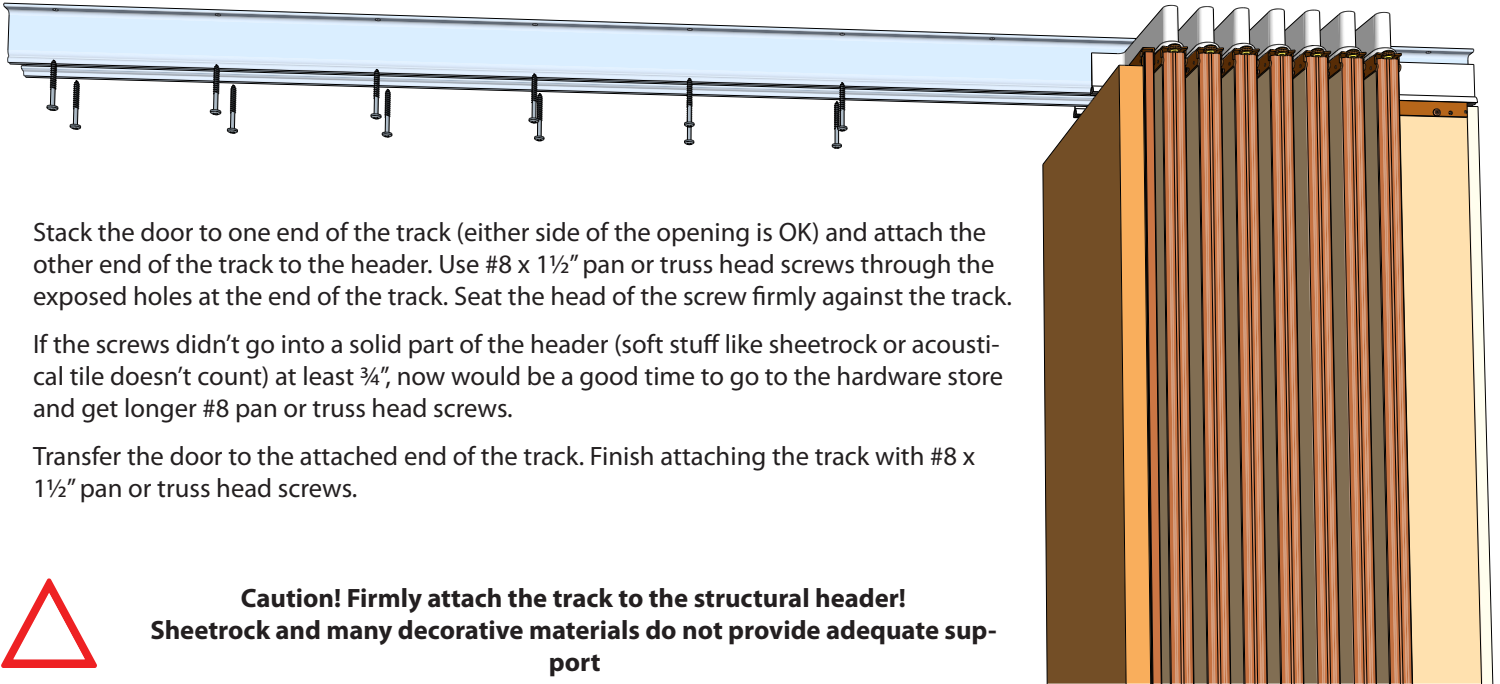

Stack the door to one end of the track (either side of the opening is OK) and attach the other end of the track to the header. Use #8 x 1½" pan or truss head screws through the exposed holes at the end of the track. Seat the head of the screw firmly against the track.

If the screws didn't go into a solid part of the header (soft stuff like sheetrock or acoustical tile doesn't count) at least ¾", now would be a good time to go to the hardware store and get longer #8 pan or truss head screws.

Transfer the door to the attached end of the track. Finish attaching the track with #8 x 1½" pan or truss head screws.



**Caution! Firmly attach the track to the structural header!**  
Sheetrock and many decorative materials do not provide adequate support

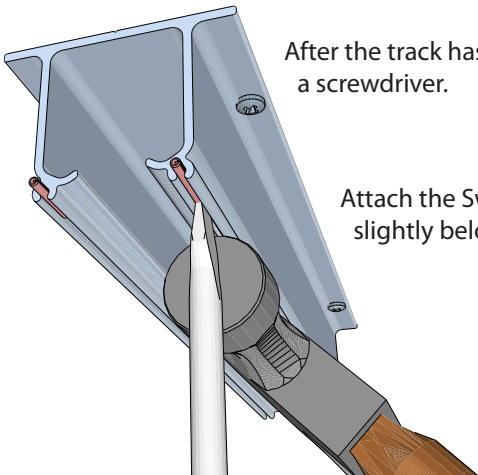

After the track has been secured, drive the alignment pins across the joints with a hammer and the edge of a screwdriver.

Attach the Sweep Moldings snugly against the Track with 8d (2½") finish nails. Set the nail heads slightly below the surface.

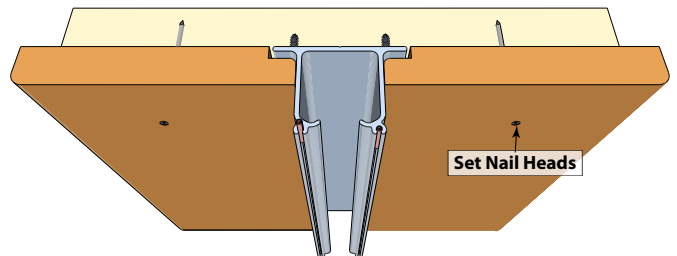

**Check it out!** Move the door back and forth along the track looking for smooth operation. Most frequent problems include wheels sideways or debris in the track.





This next section is most critical. Improperly installing the wall/jamb Mount results in the majority of trouble calls to Woodfold.

Repeat after me: **I will read this section. I will read this section.**

### 3. WALL OR JAMB MOUNTING SYSTEMS

If your door is single ended (SE) or a pair (see the top of Page 2) you need to read this Section.

If yours is a double ended (DE) door, forget the warning above and skip ahead to Section 4.

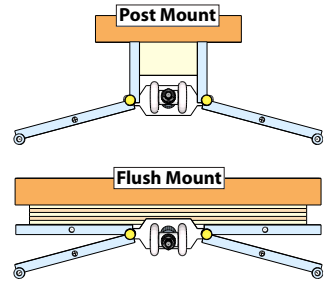

#### Post Mounting

Find the 2½" x 1¼" post in the shipping package. Attach it to the wall/jamb surface 1" below and centered on the track. Use the provided #8 x 2½" flat head screws through the pre-drilled holes in the post. Ensure the post is plumb!

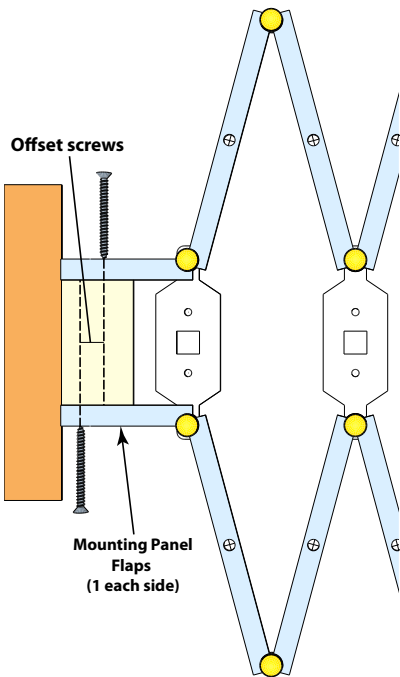
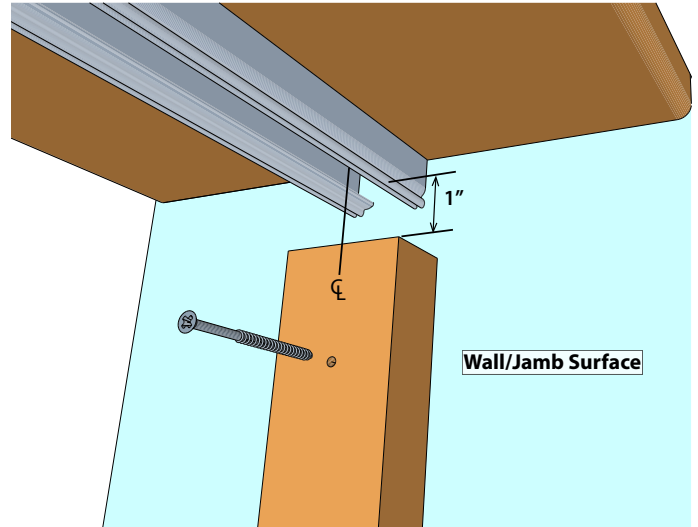

Push the door over the post. The post will snugly fit between the mounting panel flaps. Screw the mounting panel flaps to the post using the provided #6 x 1½ flat head screws. Place a screw about 6" from the top and bottom of the post and 2 additional screws equal distances between the first 2 screws. Repeat anchoring the 2nd flap being sure to slightly offset the screws so they won't meet in the middle of the post.

#### Flush Mounting

The door mounting panel comes from the factory pre-attached to a piece of plywood. Do Not Remove the plywood.

Push the door to the side that will be fastened permanently to the wall. Let the door form its own plumb (hang free) and carefully mark the wall with a pencil at the edge of the mounting panel/plywood near the top and bottom of the door.

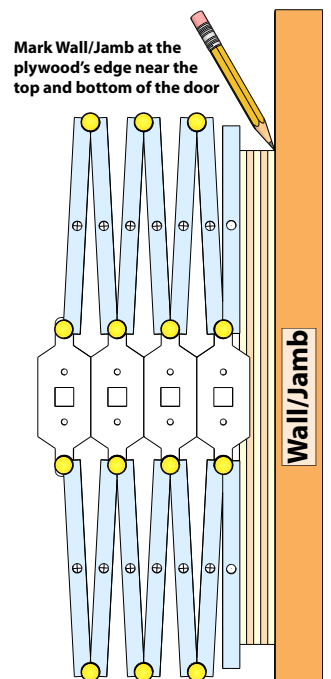

**It is important! Make the marks while the door is in its stacked position or the door will not close properly.**



OK! Here comes the critical step. You just marked the wall at the top and bottom of the mounting panel edge with the door stacked. Now, extend the door to have access to the Mounting Panel. Hold the Mounting Panel edge at the pencil marks at both top and bottom!



Caution! Take care when attaching the Mounting Panel to the wall. As you unfold the door to insert the screws, the position of the Mounting Panel may move away from your marks. Sometimes, the marks look “off” when the door is extended.

### **Trust your marks!**

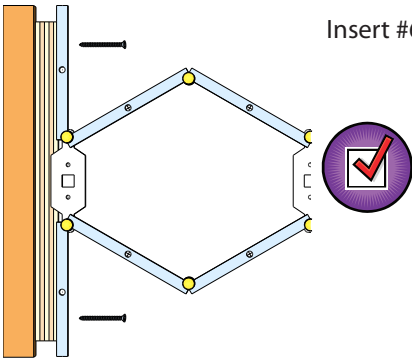

Insert #6 x 1½” flat head screws about 8” up from the floor and 8” down from the track on both sides.

**Check it out!** Can you see the pencil marks? If not, the door has shifted. If there is a gap between the edge and your marks, the door has shifted the other way. Stack the door against the Mounting Panel; it should form a neat, tight stack. DON'T Force it. If it binds, you missed your marks!

When the door stacks properly, re-extend it and install 2 more screws on each side between the first 2, about equal distances apart.

## 4 INTERLOCKING JAMB MOLDING

The Interlocking Jamb Molding is the extruded aluminum piece into which the door latches.

If your door is a Pair, and slides from each end to meet in the middle, your Interlocking Jamb Molding is already installed on a lead post of the door and you may disregard this section.

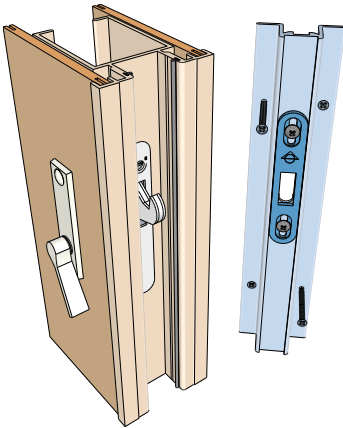

### **Hook style catch**

Dry fit the Interlocking Jamb Molding against the wall, directly under the track. It should fit snugly against the wall and the track at the top. If it needs to be trimmed, trim it at the **BOTTOM**. The arrow sticker on the back pointing up can easily determine top and bottom. The latch slot should correspond to the hook of the latch.

Attach the interlocking jamb molding with #6 x 1½” flat head screws, through the pre-drilled holes and into the wall behind.

Shut the door, latch it and wiggle the handle a bit. The Latch should swing fully up with the Lead Post pulled snugly against the Interlocking Jamb Molding.

If the fit is too loose, or too tight, open the door and adjust the mechanism with a screwdriver.

Turn the Adjusting Screw clockwise ↻ to loosen the fit, counterclockwise ↻ to tighten.

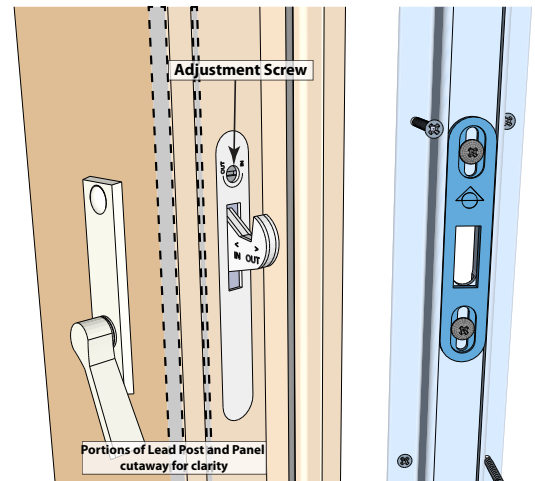

## Magnetic Latch

Dry fit the Interlocking Jamb Molding against the wall, directly under the track. It should fit snugly against the wall and the track at the top. Each jamb molding is pre-cut to fit the opening, however, trim the molding with a hacksaw at the bottom if needed.

Attach the Interlocking Jamb Molding to the wall with #6 x 1½" flat head screws.

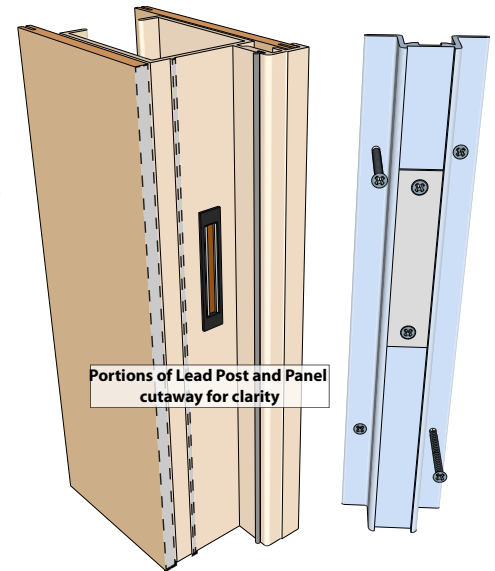

***Check it out!*** Open and close the door a few times then step back and admire your work.

***Installation is complete!***

## 5 UPKEEP AND CARE SUGGESTIONS

OK! Now the door is installed, let's review it's love and care.

### Operation/Maintenance

- For proper operation the track must be securely attached to the header, plumb and level. Vertical jambs must be perpendicular for proper operation. Use instructions for proper installation
- Do not rapidly pull or force any folding door across openings or around corners
- The hinge system may be stiff initially and will gradually ease after a period of time with regular use
- During normal use of your Woodfold door watch for instances of binding during movement. If there is binding, inspect the track for loose screws, dirt, debris and wheel alignment.
- Track may be periodically lubricated with a petroleum jelly type material. Do not use aerosol lubricants

### Care/Cleaning

- Avoid exposure to excess or continued moisture
- As with all materials, exposure to light will cause fading
- Regular cleaning of the Vinyl/Acrylic/Aluminum/Veneer- use mild soapy water then dry with a soft cloth or chamois. Do NOT use household cleaners, abrasive towels or scouring pads.
- Wood veneer doors can be treated periodically using a furniture polish/cleaner
- Acrylic/Aluminum panel doors can be treated periodically with non-abrasive anti-static cleaner to reduce dust accumulation

***Thank you for purchasing a Woodfold door.***

