

# WOODFOLD



## 240 SERIES ILLUSTRATIONS

DOOR SERIES: 240

BULLETIN 240-110420

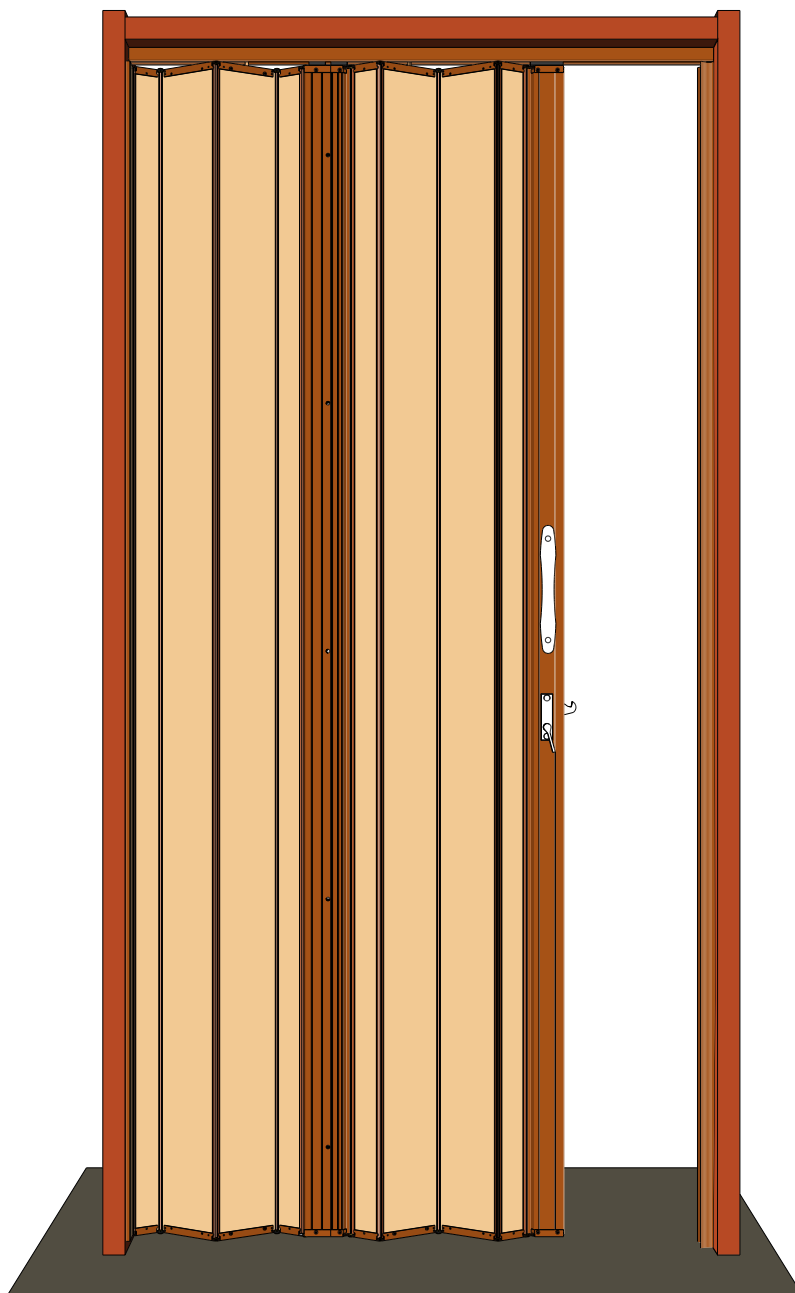

Woodfold Mfg., Inc  
P.O. Box 346  
Forest Grove, OR 97116

Voice [503] 357-7181  
Fax: [503] 357-7185  
[www.woodfold.com](http://www.woodfold.com)

# MAJOR GROUPS

## Track Group



**Mounting Panel Group**

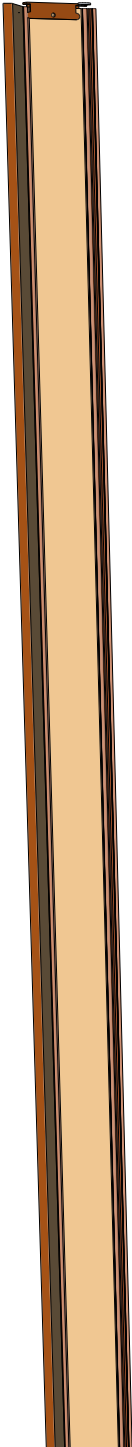

**Intermediate Rolling Post Group**

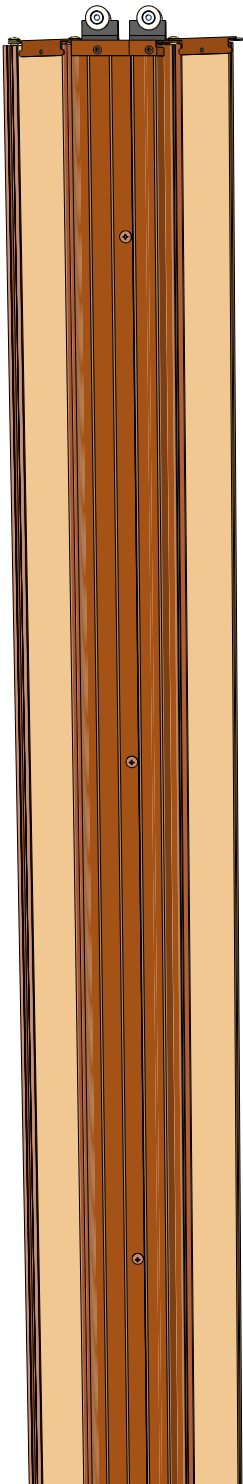

**Body Panel Group**

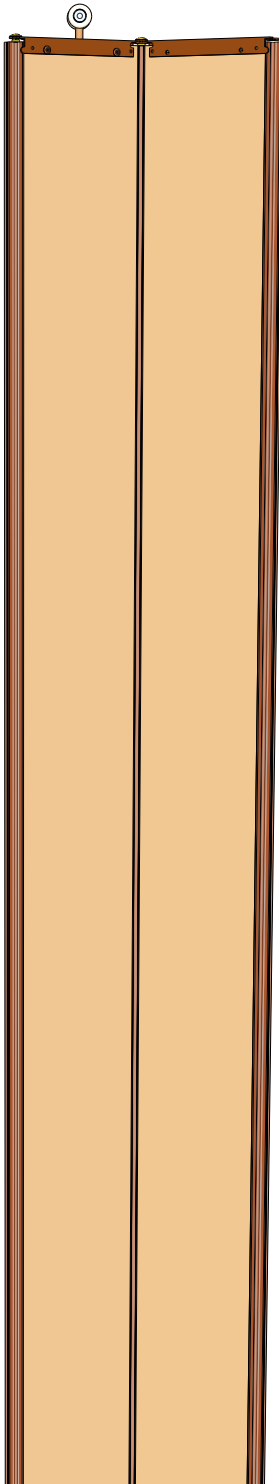

**Lead Post and Attachments Groups**

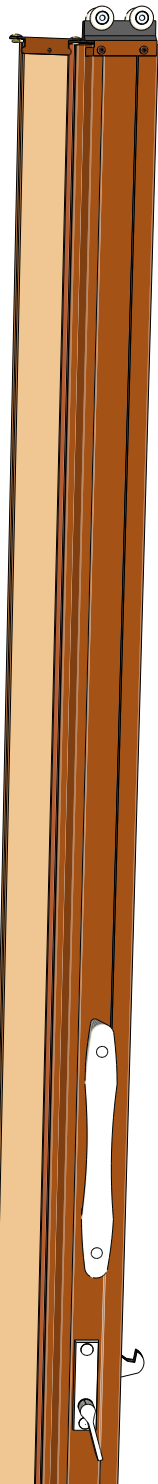

**Interlocking Jamb Molding Group**

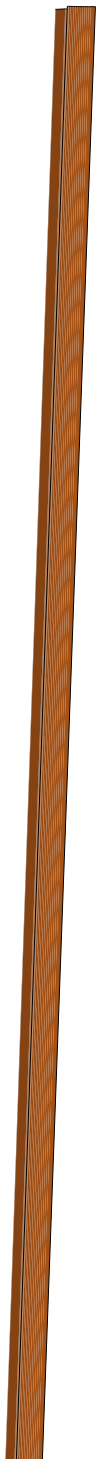

# MOUNTING PANEL GROUP

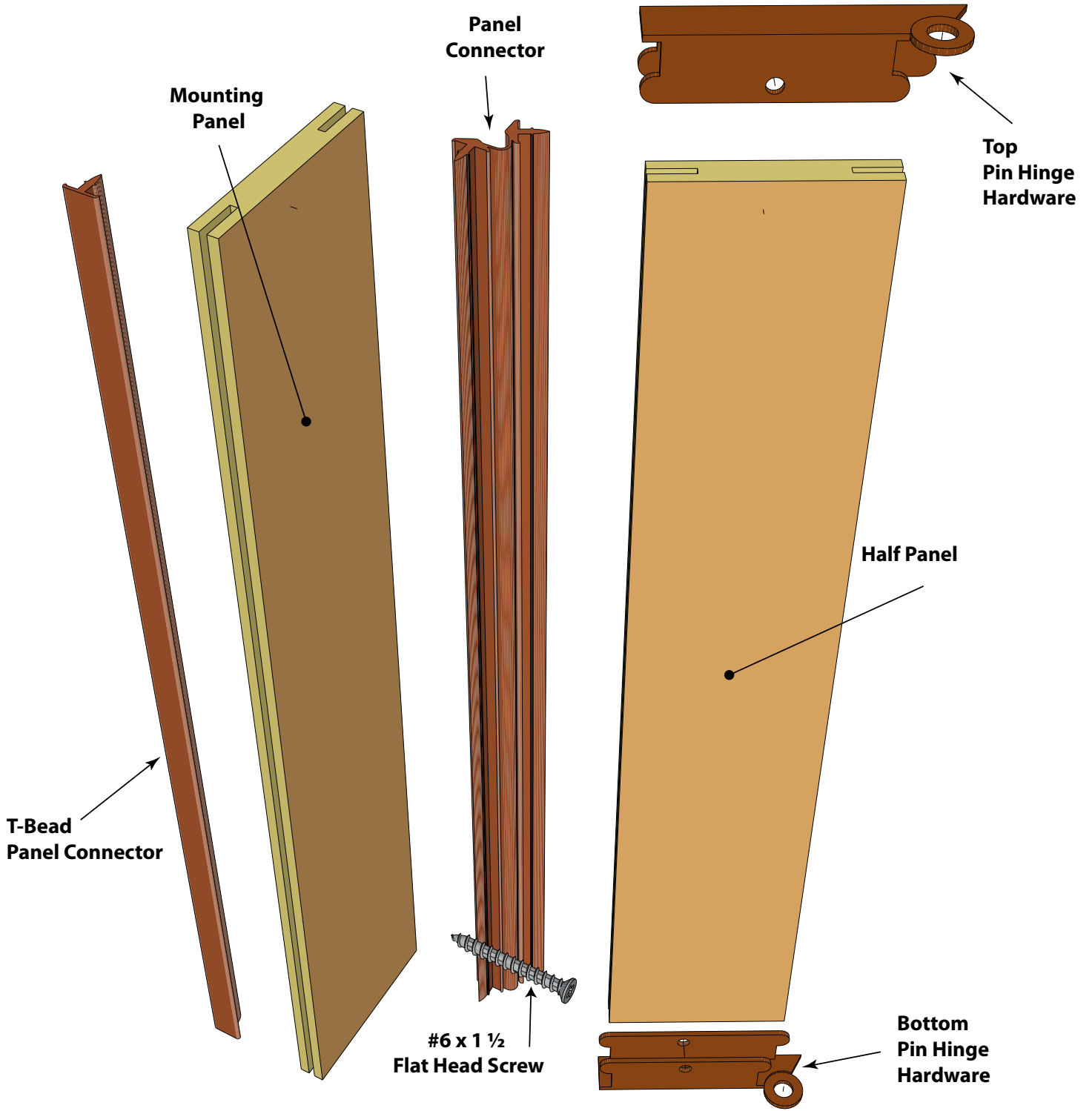

# INTERMEDIATE ROLLING POST GROUP

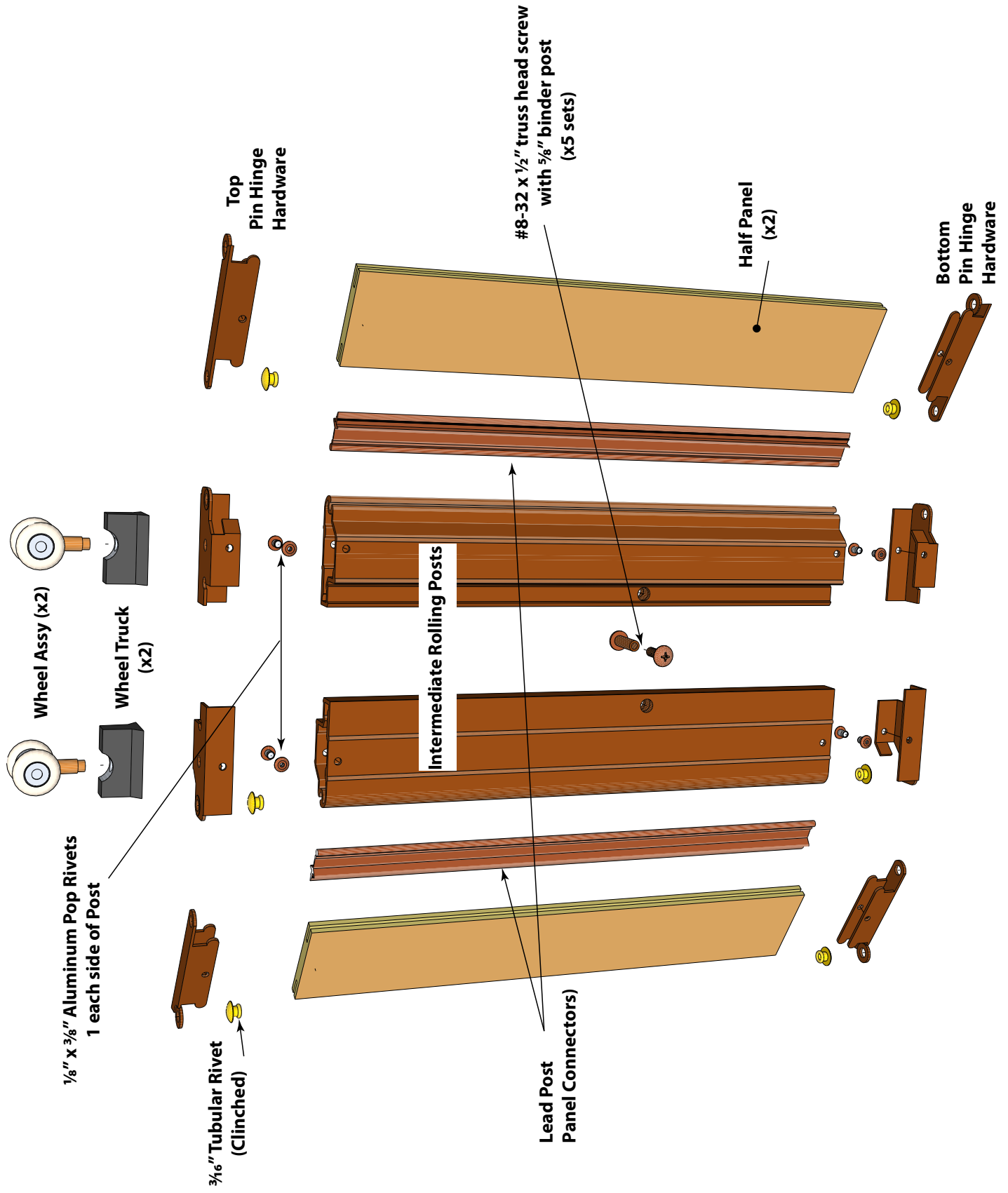

# BODY PANEL GROUP

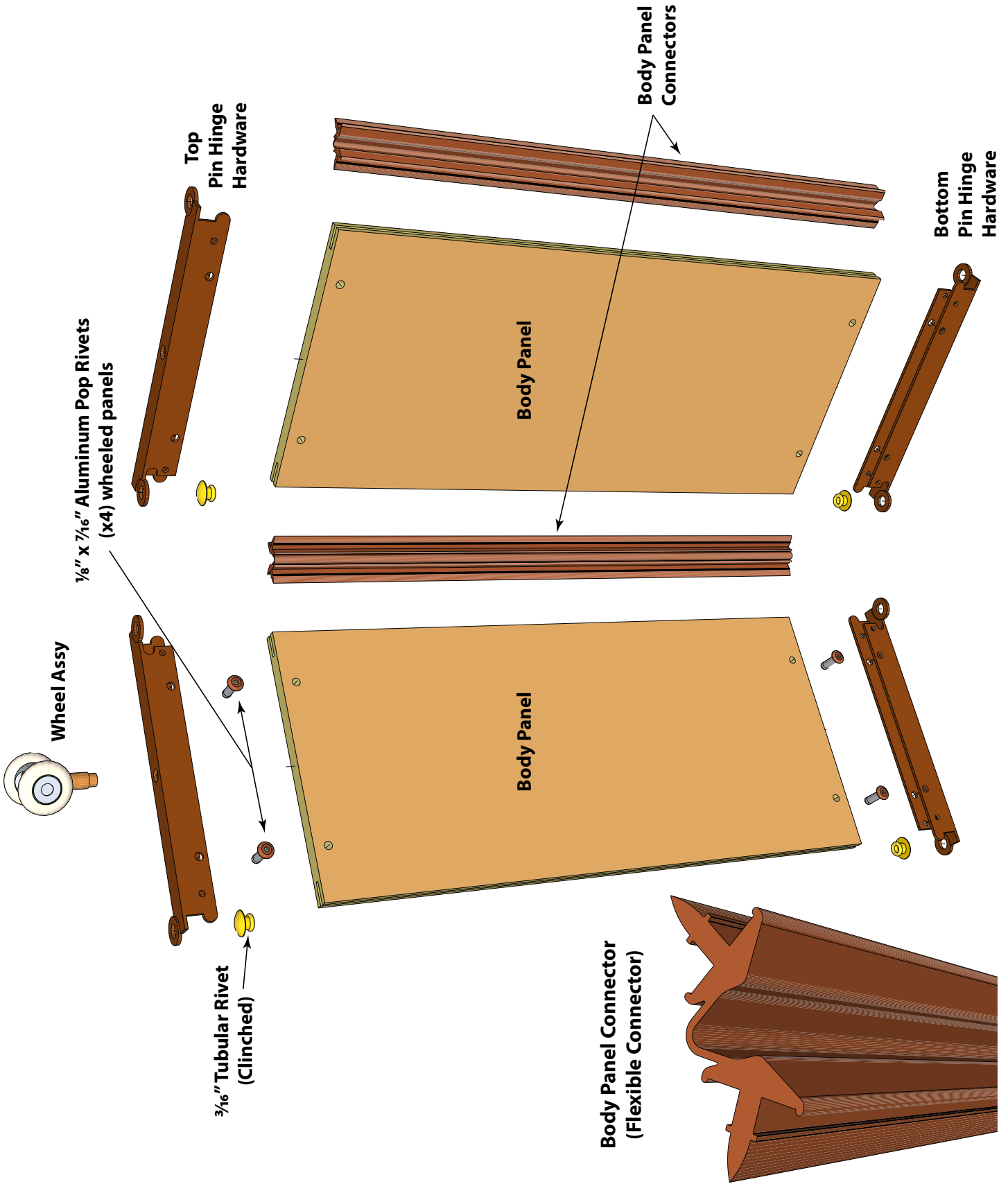

# LEAD POST GROUP

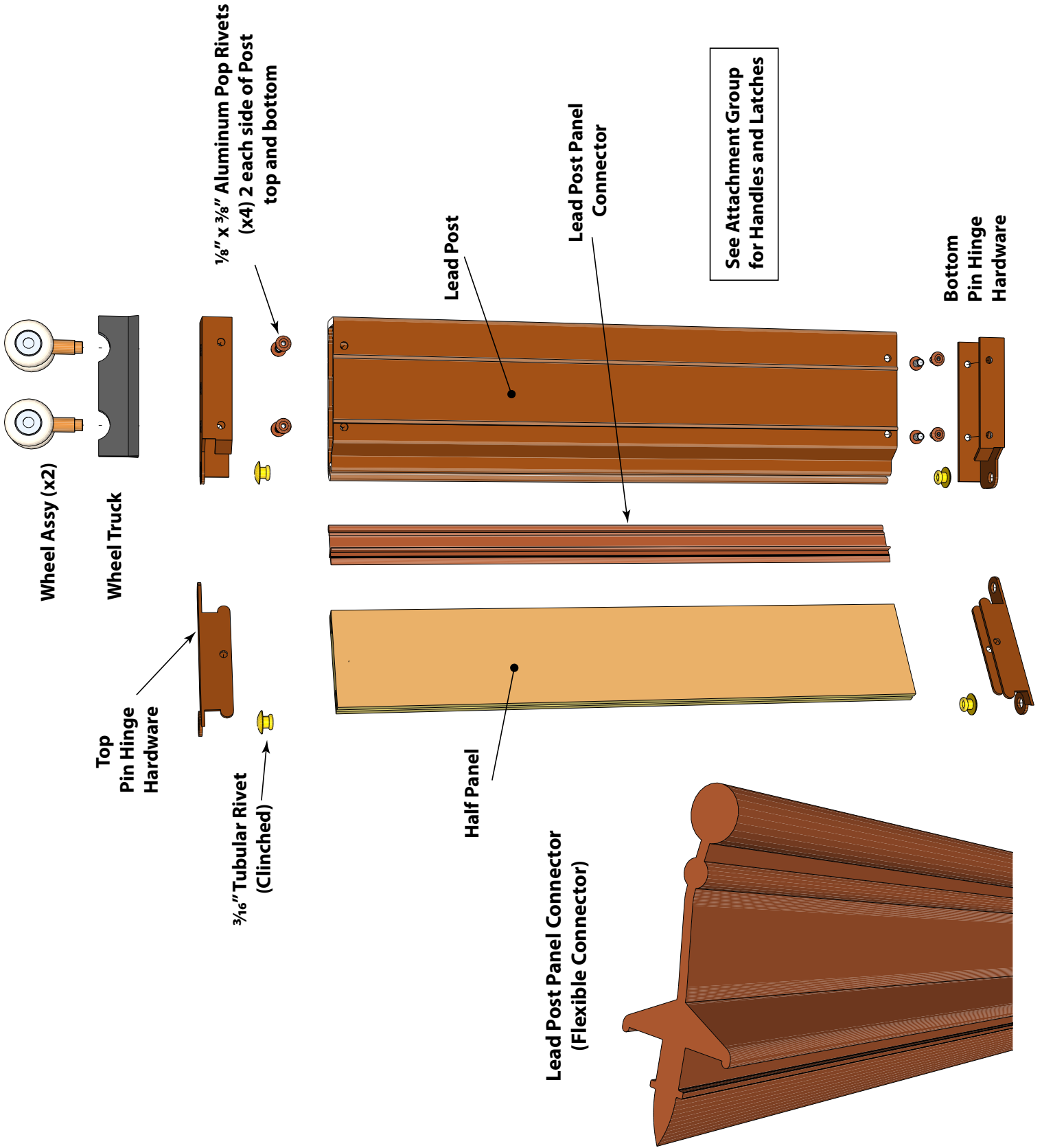

# LEAD POST ATTACHMENT GROUP

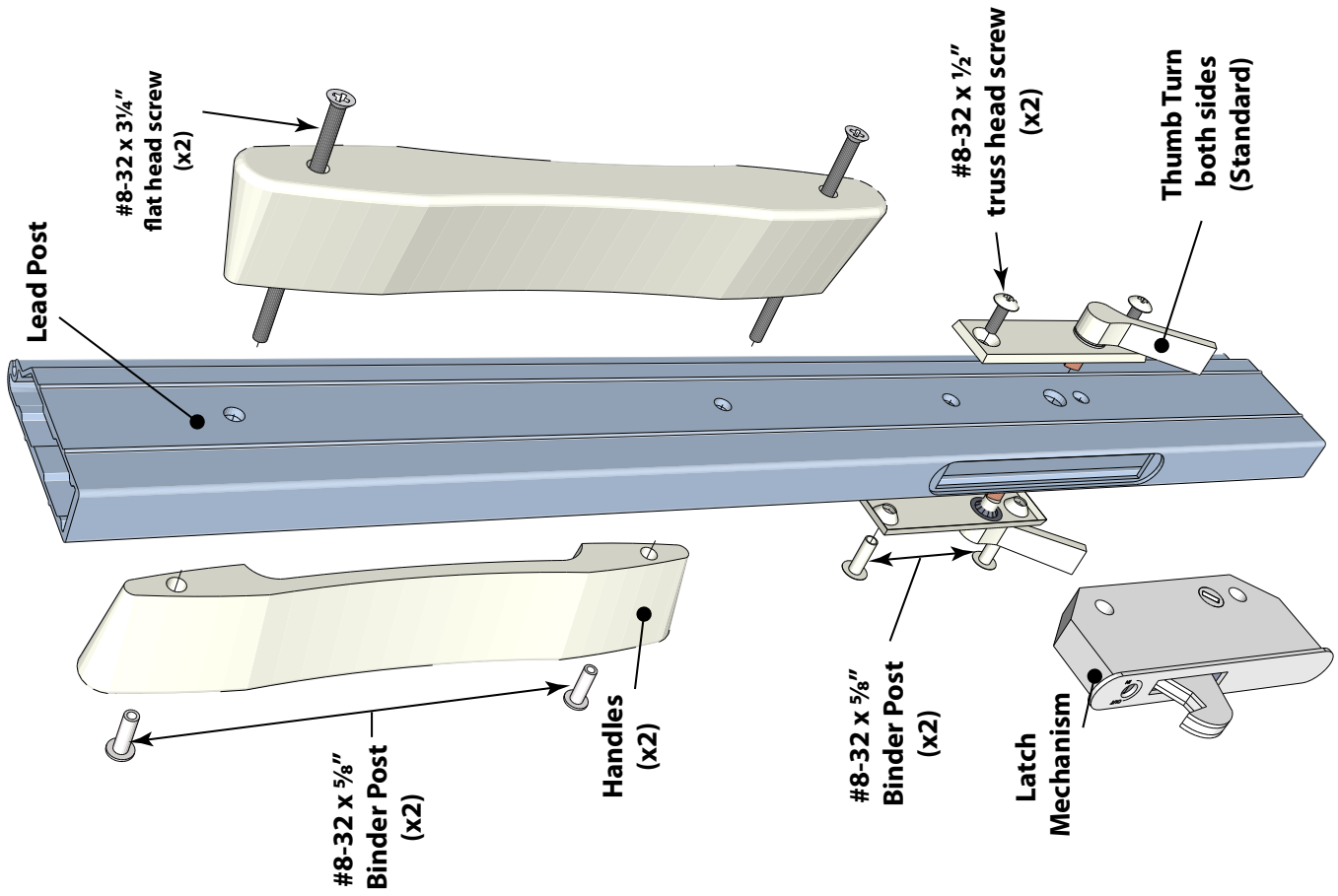

## LATCH OPTIONS

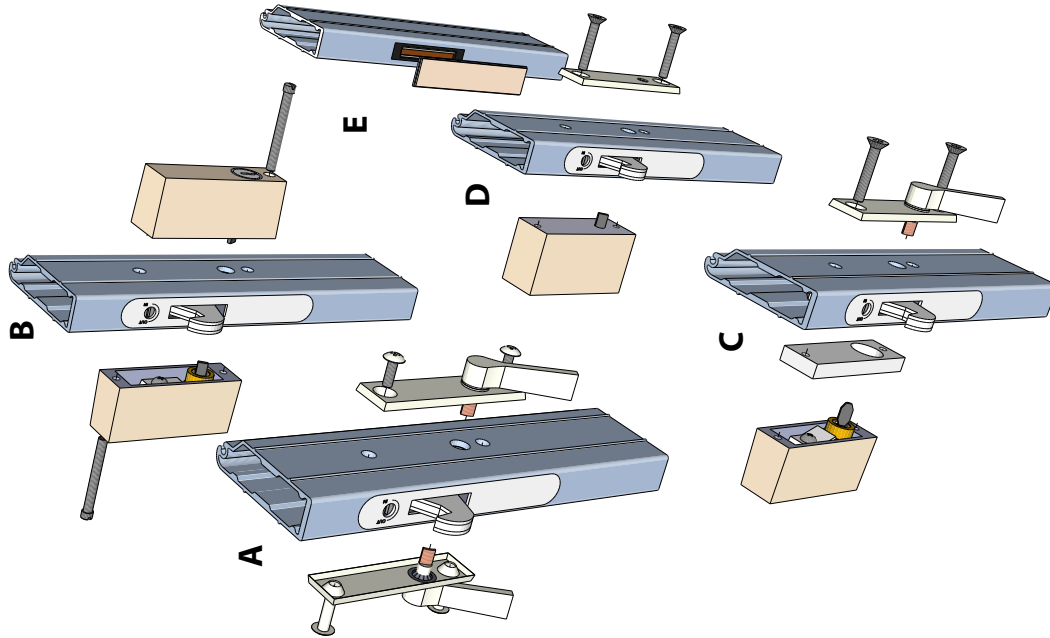

- A. Thumb Turn - both sides (standard)
- B. Key Lock - both sides (option)
- C. Key Lock & Thumb Turn combination (option)
- D. Key Lock & Strike Plate combination (option)
- E. Magnetic Catch & Strike Plate (option)



# TRACK AND INTERLOCKING JAMB MOLDING GROUPS

## Track Options

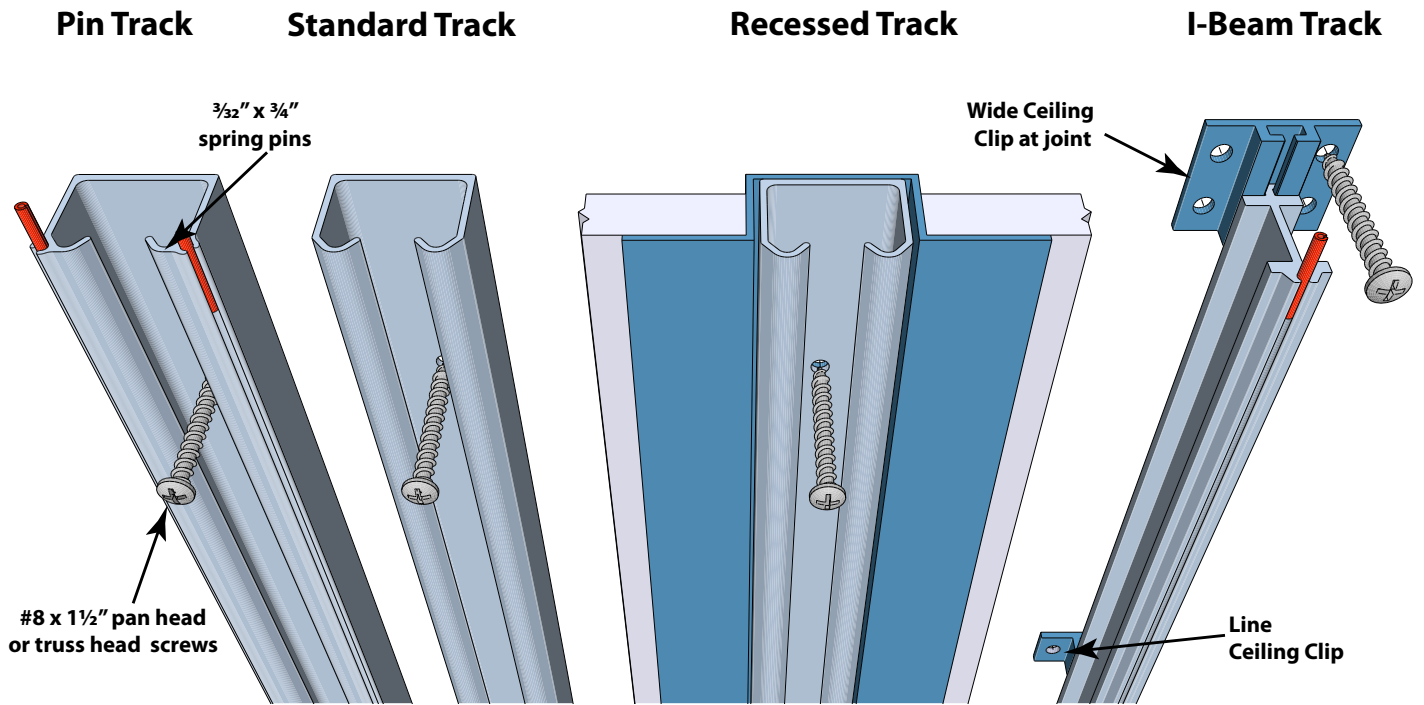

## Interlocking Jamb Molding (IJM)

