

# WOODFOLD



## 440 SERIES ILLUSTRATIONS

DOOR SERIES: 440

BULLETIN 440-110420

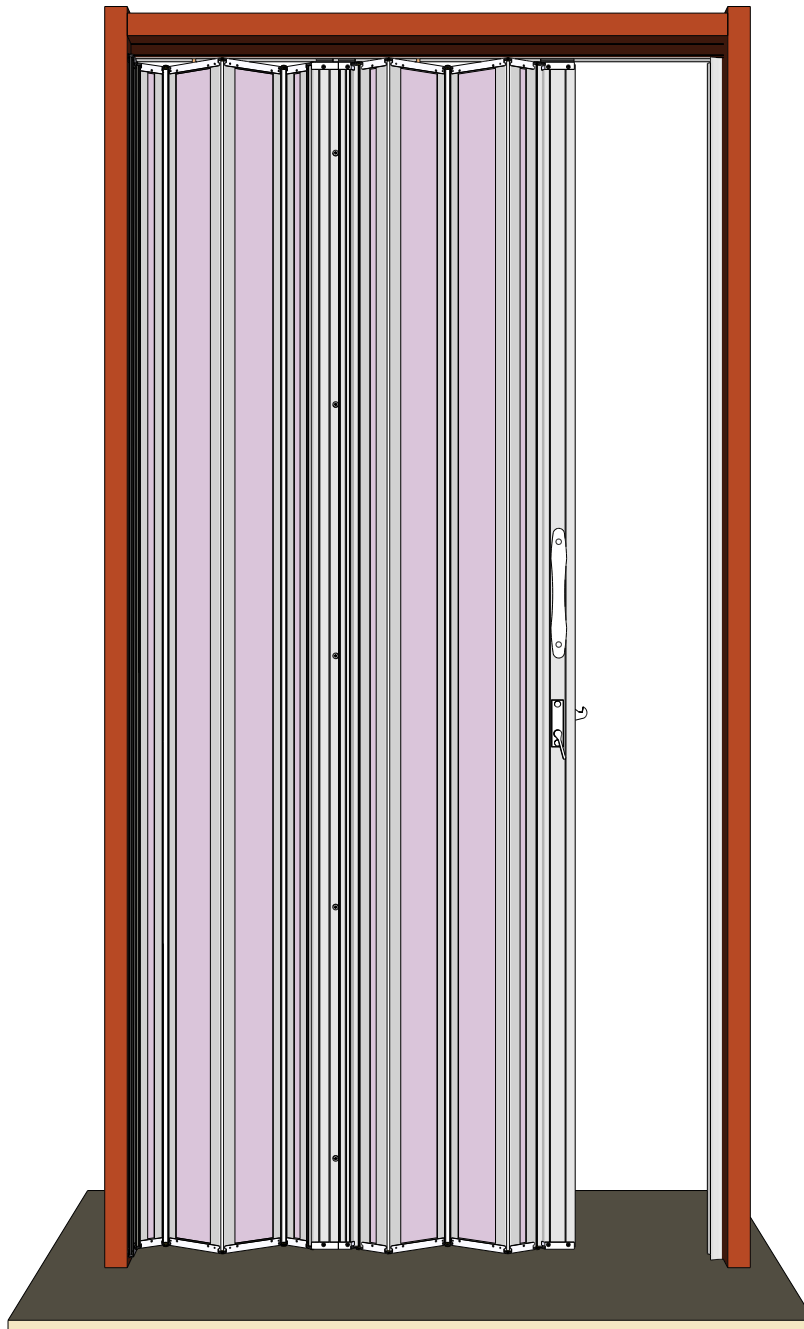

Woodfold Mfg., Inc  
P.O. Box 346  
Forest Grove, OR 97116

Voice [503] 357-7181  
Fax: [503] 357-7185  
[www.woodfold.com](http://www.woodfold.com)

# Track Group



**Mounting Panel Group**

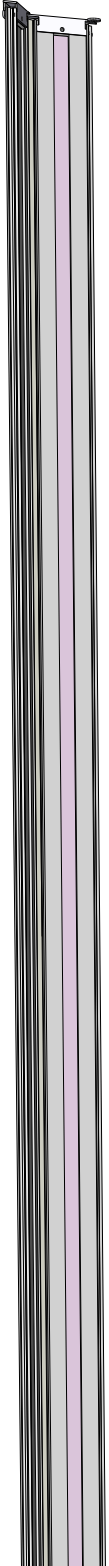

**Intermediate Rolling Post Group**

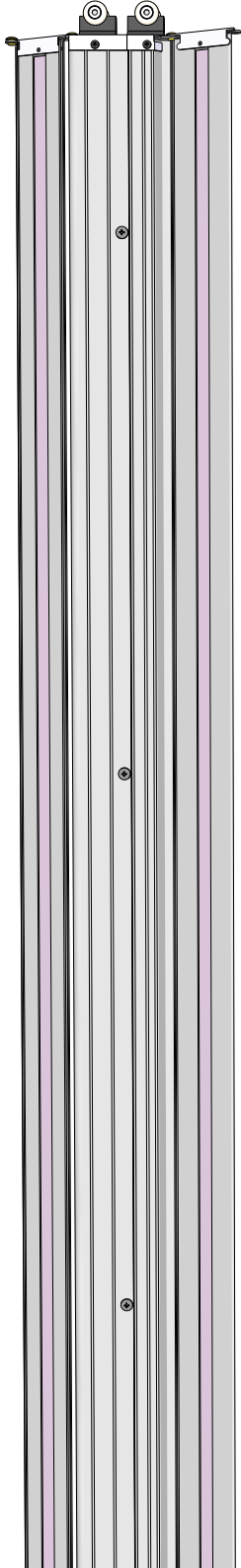

**Body Panel Group**

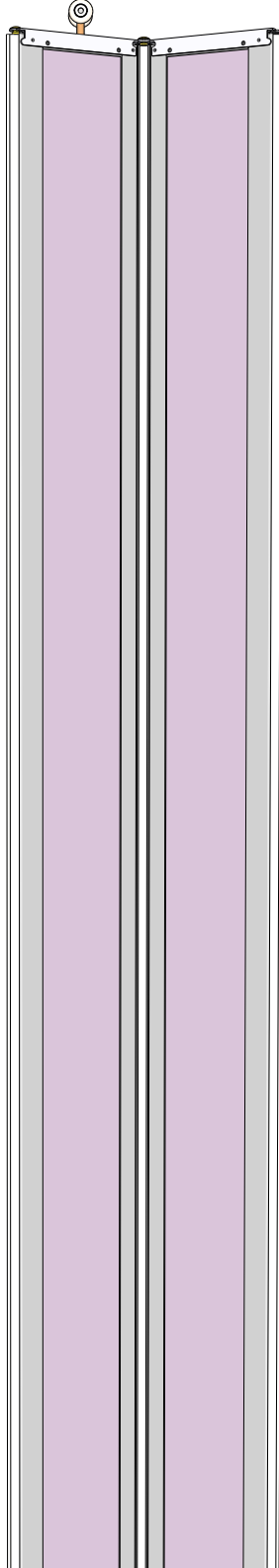

**Lead Post and Attachments Groups**

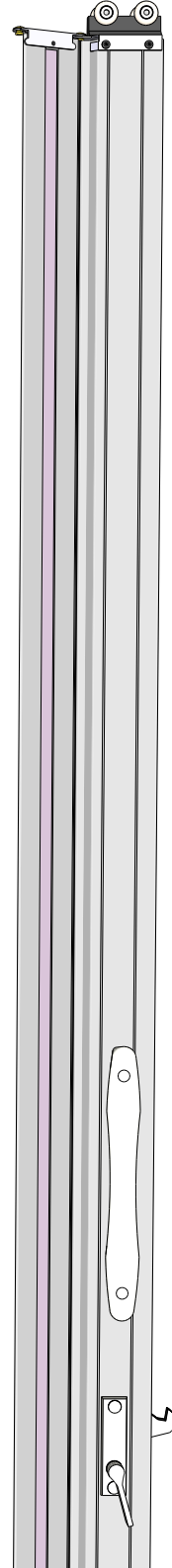

**Interlocking Jamb Molding Group**

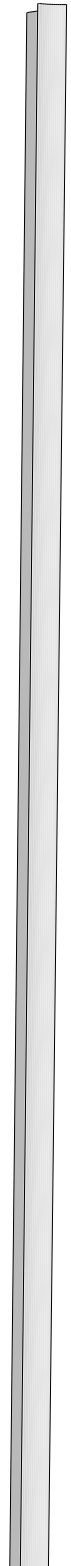

# ANATOMY OF A 440 SERIES PANEL

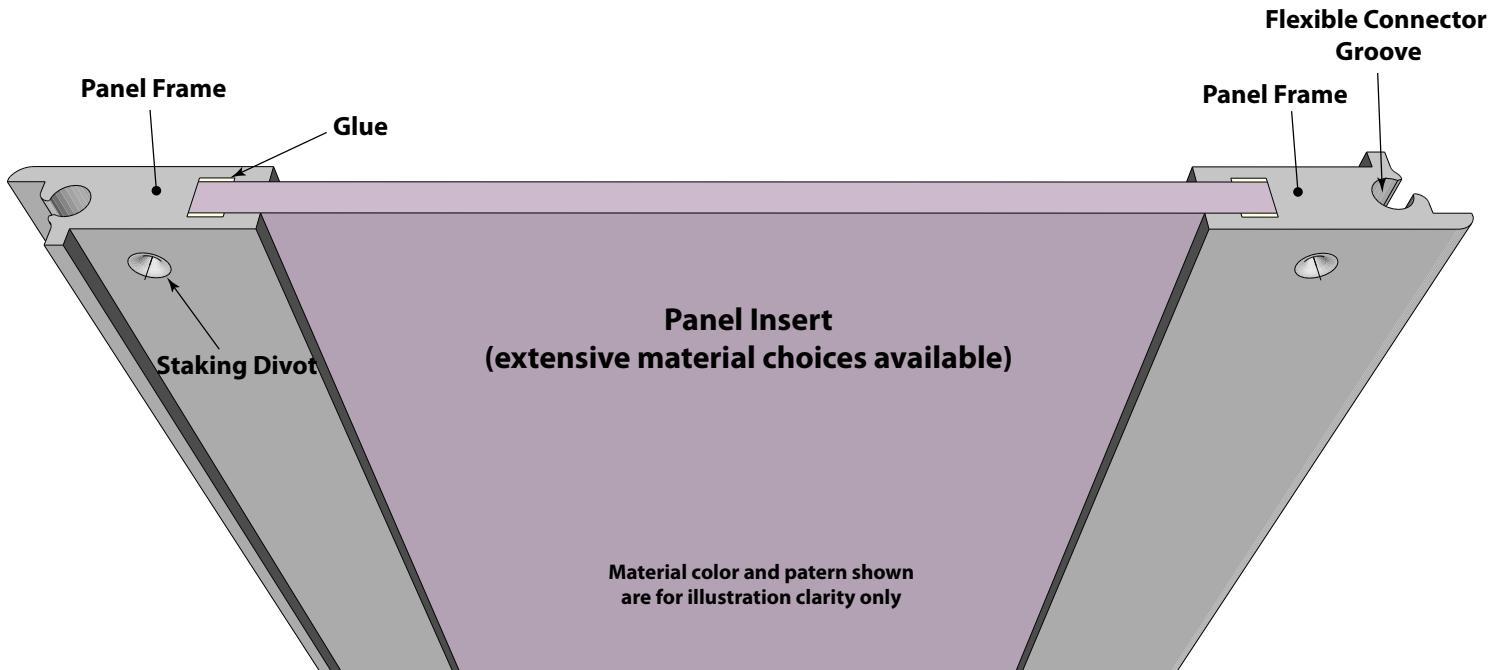

## FLEXIBLE CONNECTORS

**Lead Post Panel Connector**

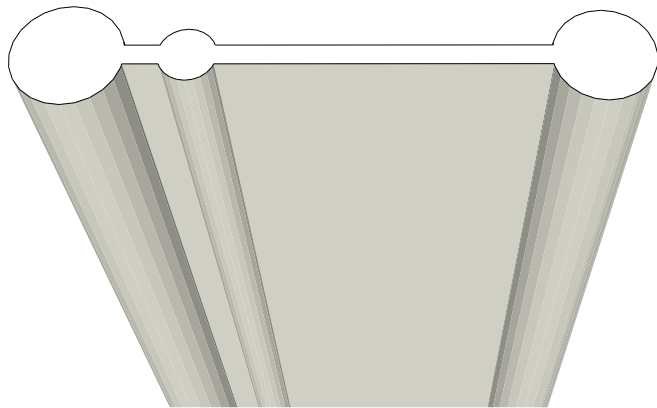

**Body Panel Connector**

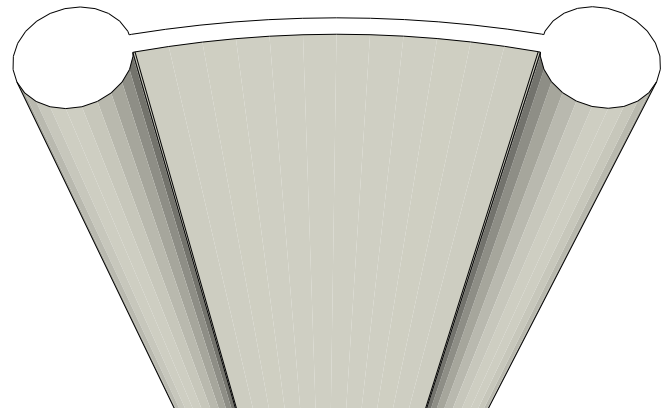

# MOUNTING PANEL GROUP

$\frac{3}{16}$ " Tubular Rivet  
(Clinched) → 

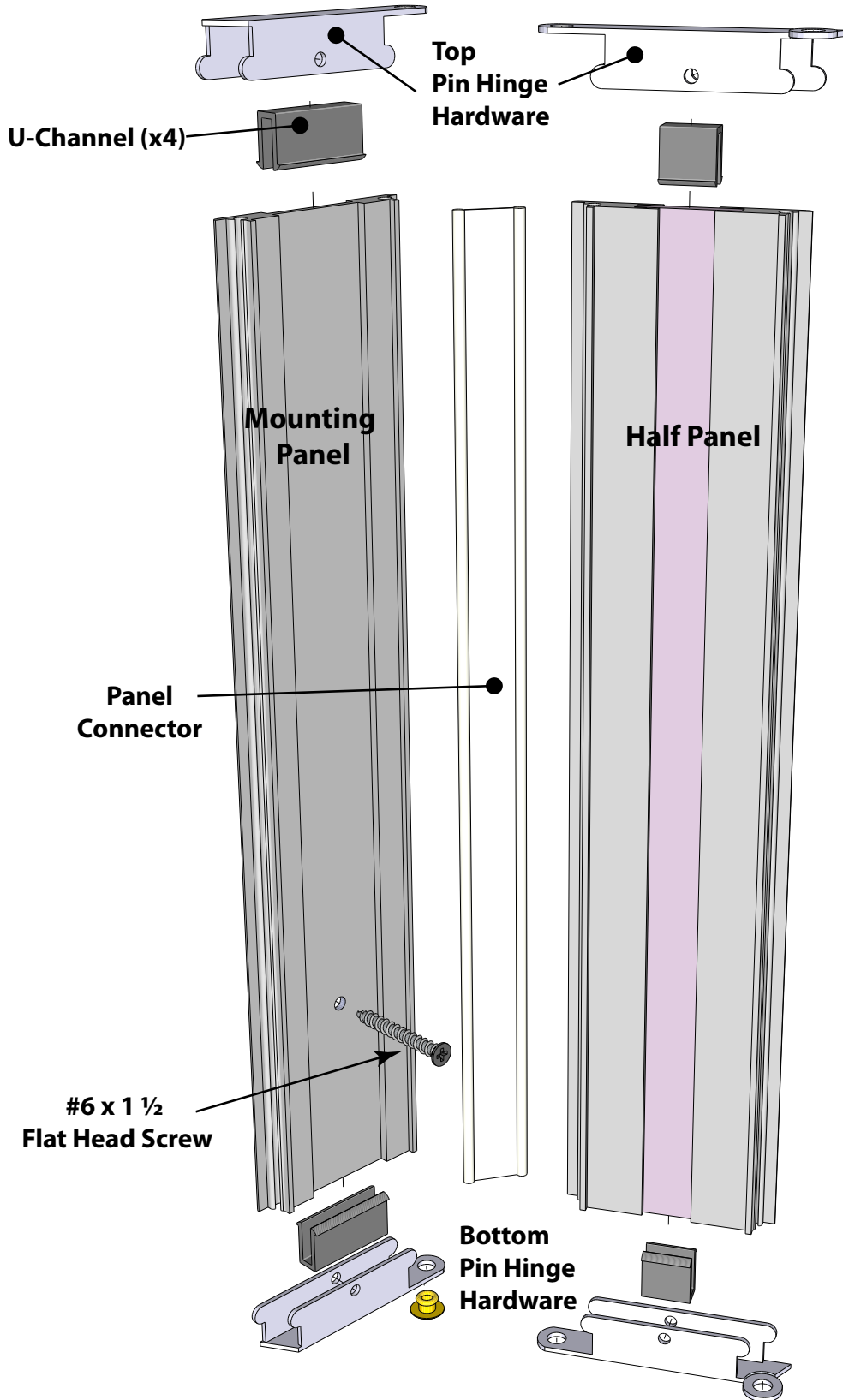

# INTERMEDIATE ROLLING POST GROUP

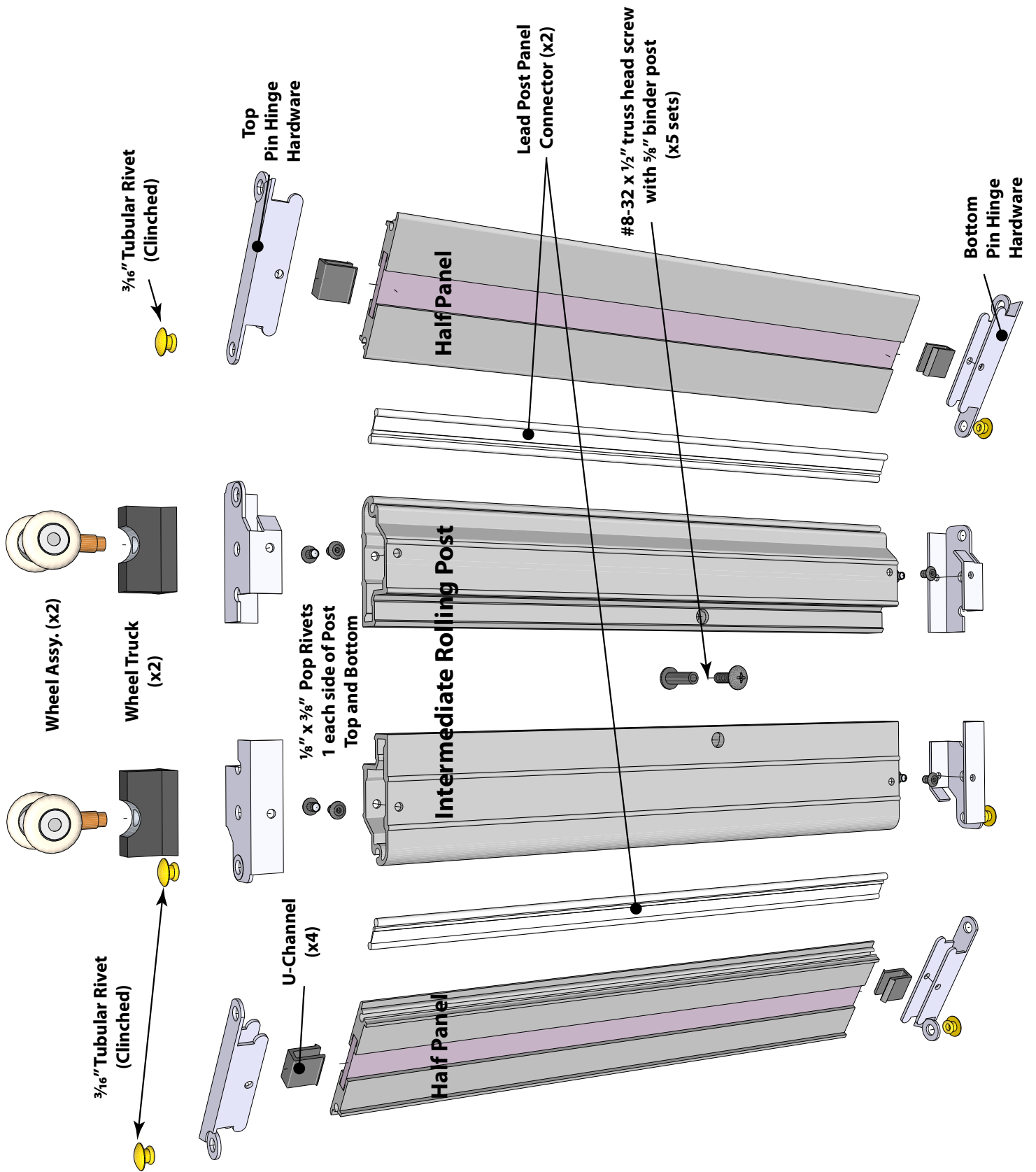

# BODY PANEL GROUP

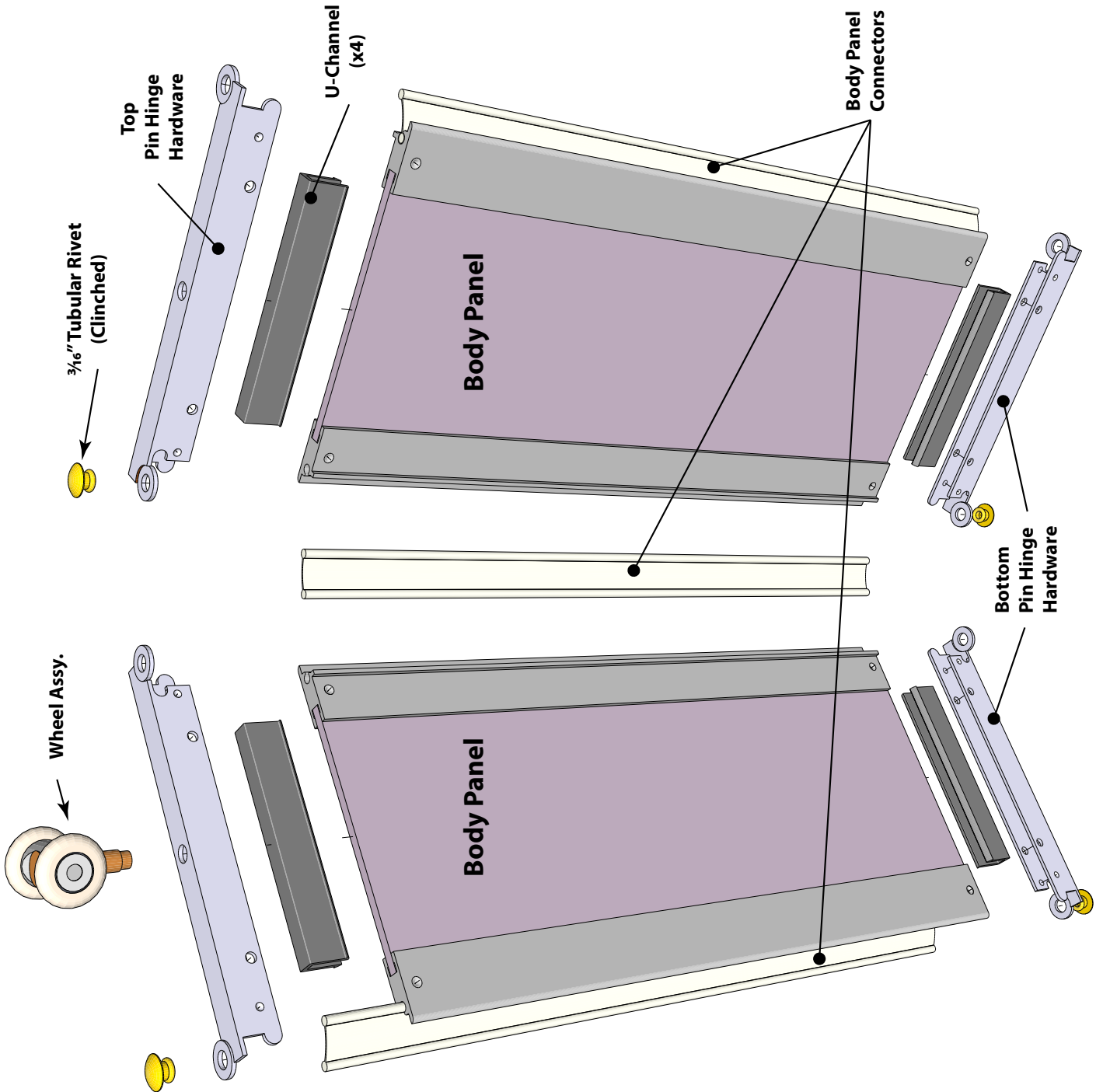

# LEAD POST GROUP

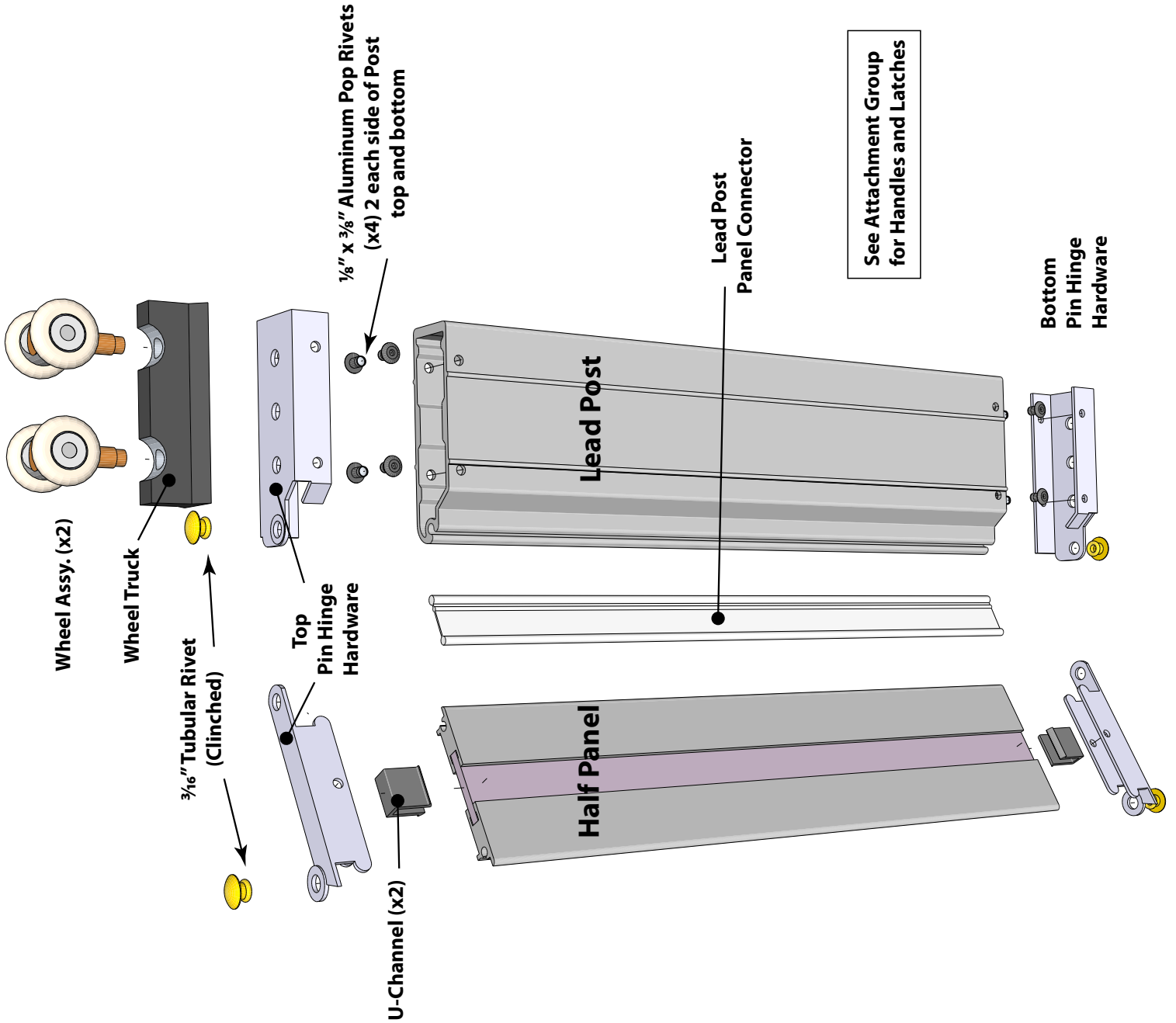

# LEAD POST ATTACHMENTS

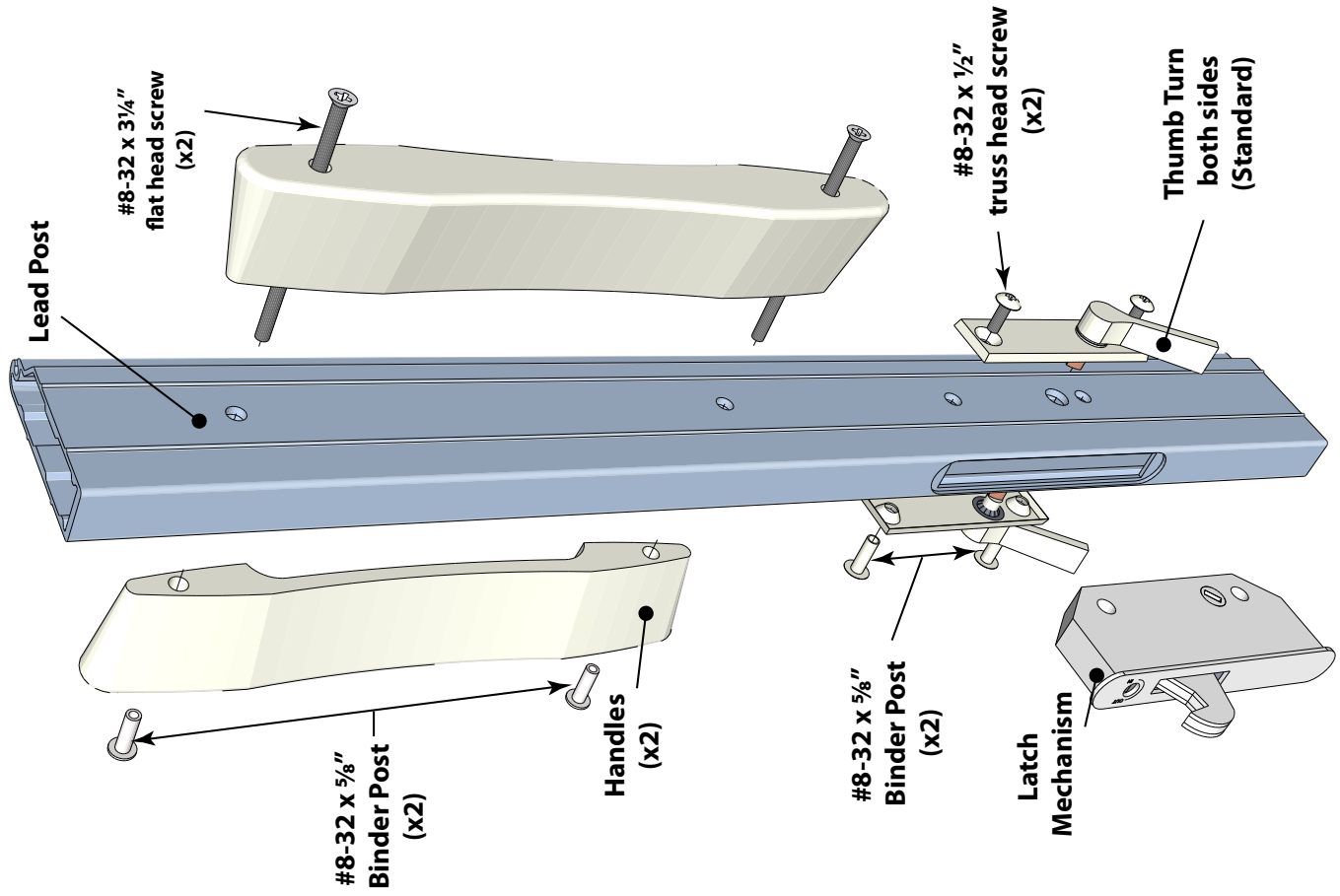

## LATCH OPTIONS

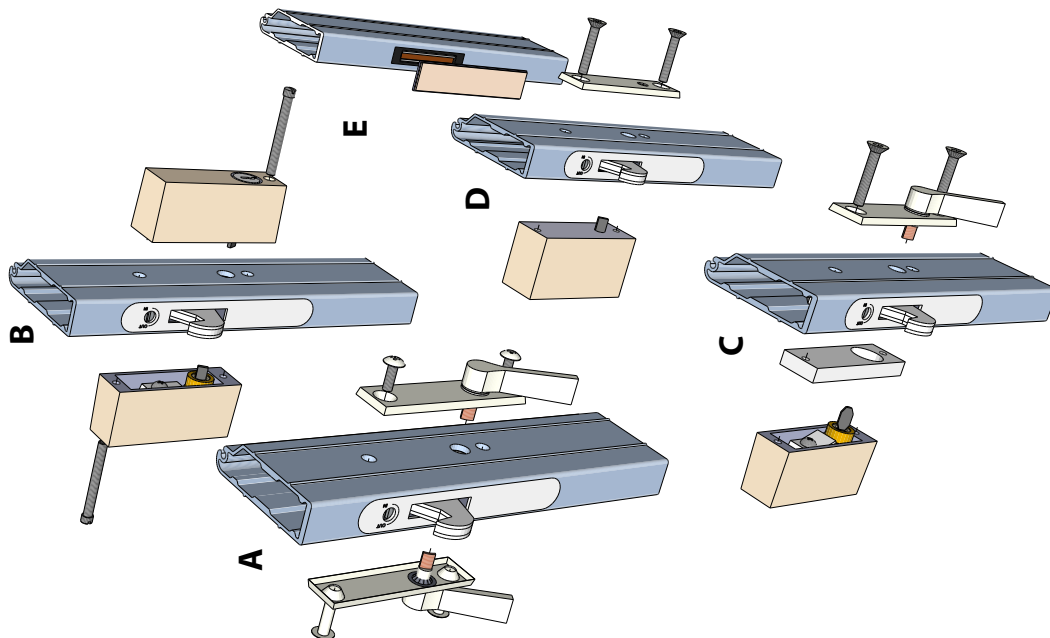

- A. Thumb Turn - both sides (standard)
- B. Key Lock - both sides (option)
- C. Key Lock & Thumb Turn combination (option)
- D. Key Lock & Plate combination (option)
- E. Magnetic Catch & Strike Plate (option)





# TRACK AND INTERLOCKING JAMB MOLDING GROUP

## Track Options

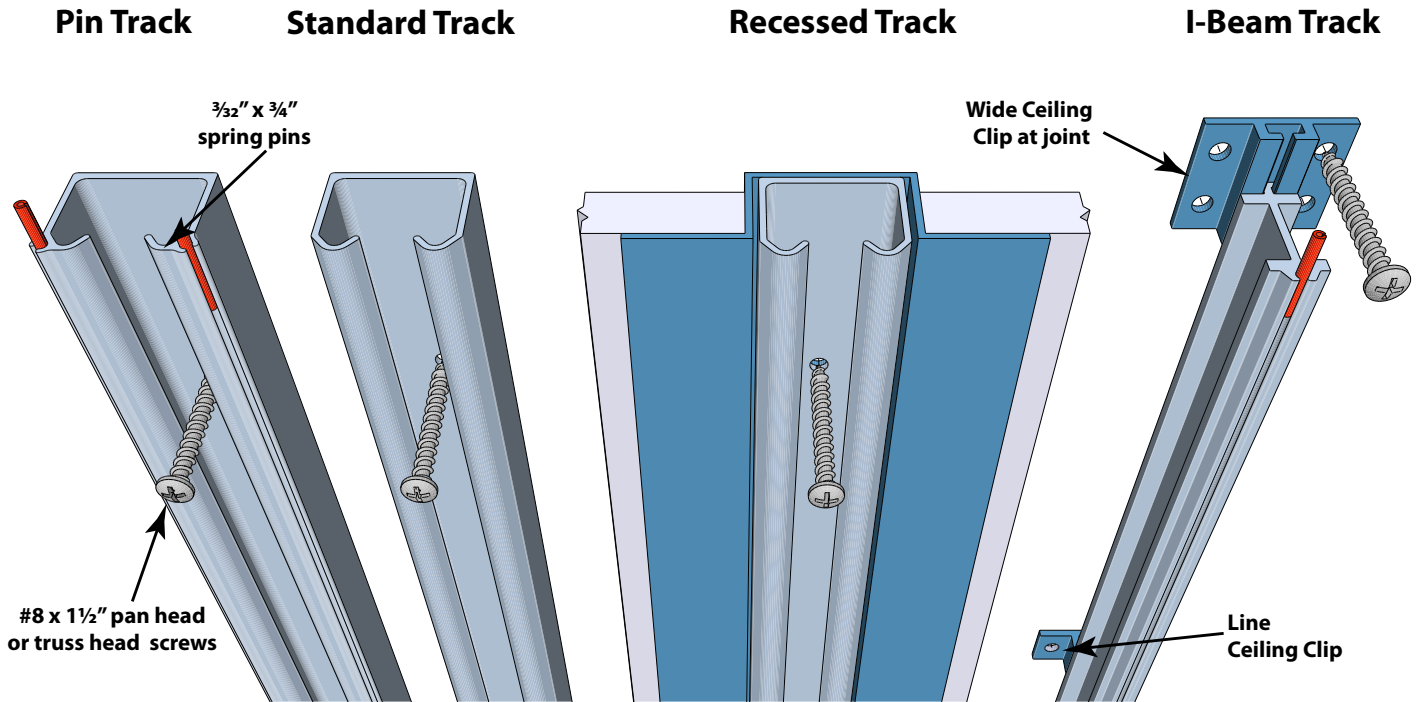

## Interlocking Jamb Molding (IJM)

