

WOODFOLD

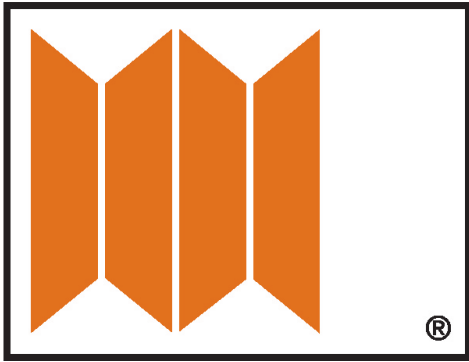

2100 SERIES ILLUSTRATIONS

DOOR SERIES: 2100

BULLETIN 2100-110420

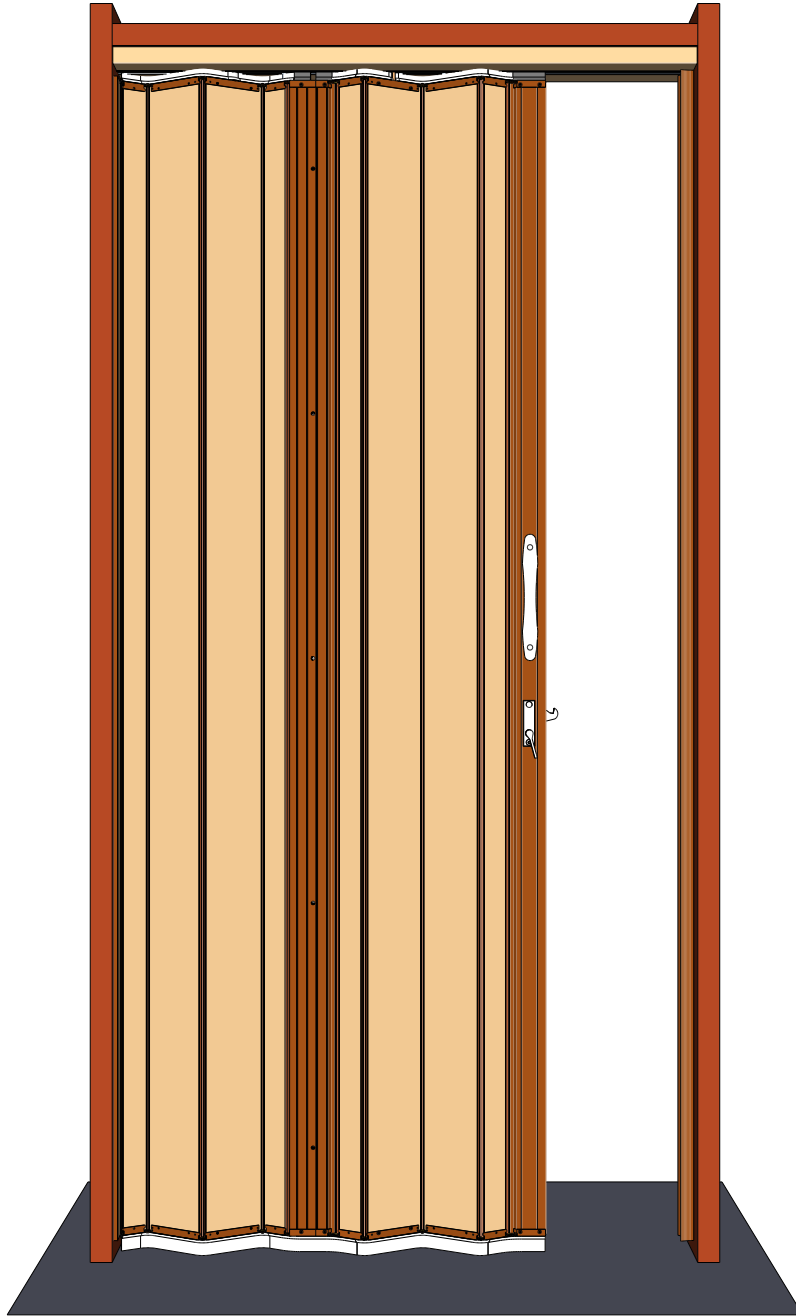

Woodfold Mfg., Inc
P.O. Box 346
Forest Grove, OR 97116

Voice [503] 357-7181
Fax: [503] 357-7185
www.woodfold.com

MAJOR GROUPS

Track Group

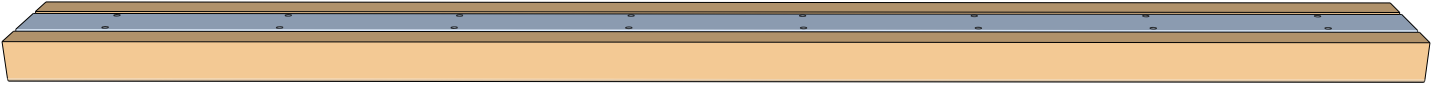

Mounting Panel Group

Intermediate Rolling Post Group

Body Panel Group

Lead Post and Attachments Groups

Interlocking Jamb Molding Group

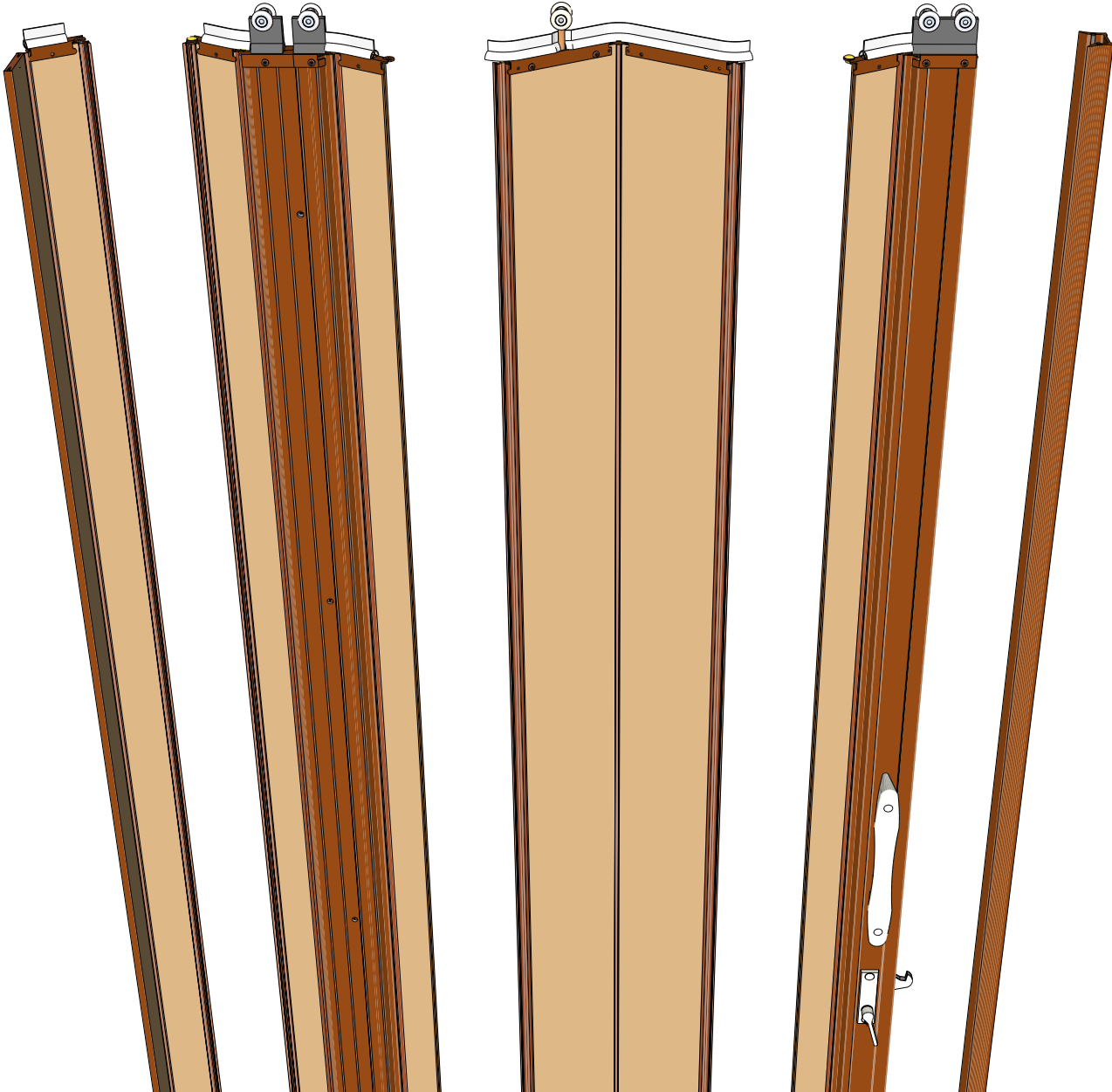

MOUNTING PANEL GROUP

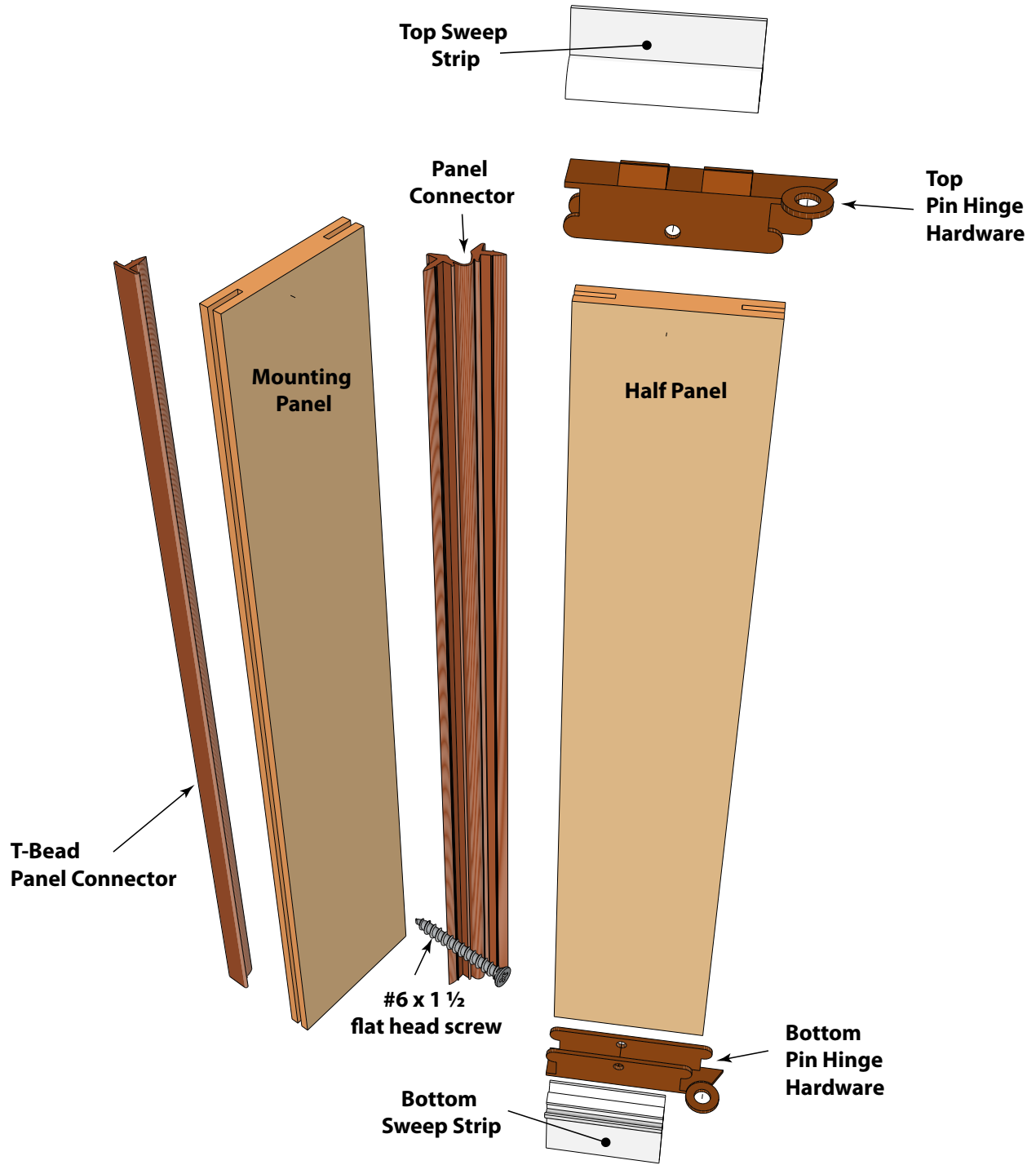

INTERMEDIATE ROLLING POST GROUP

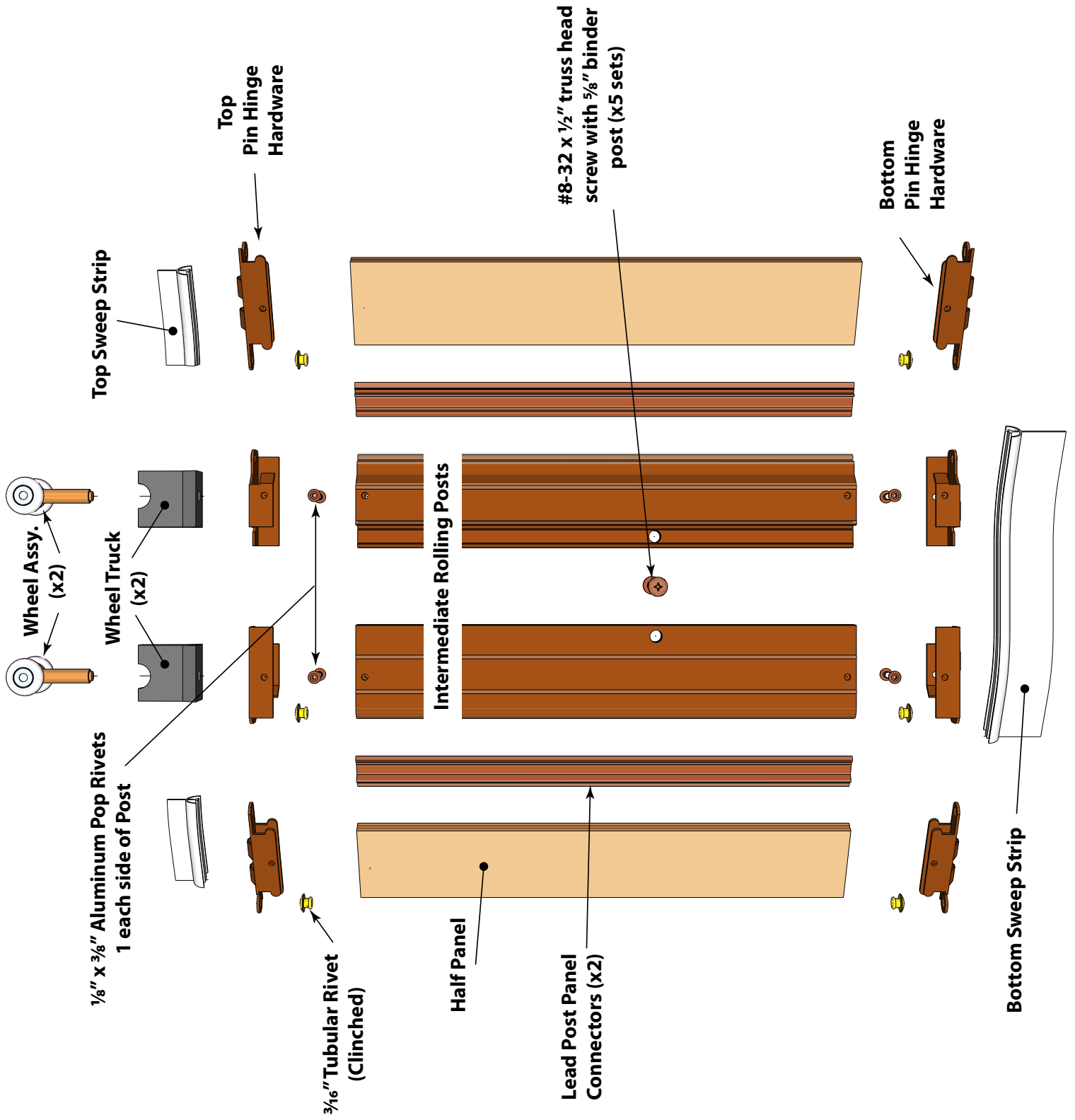

BODY PANEL GROUP

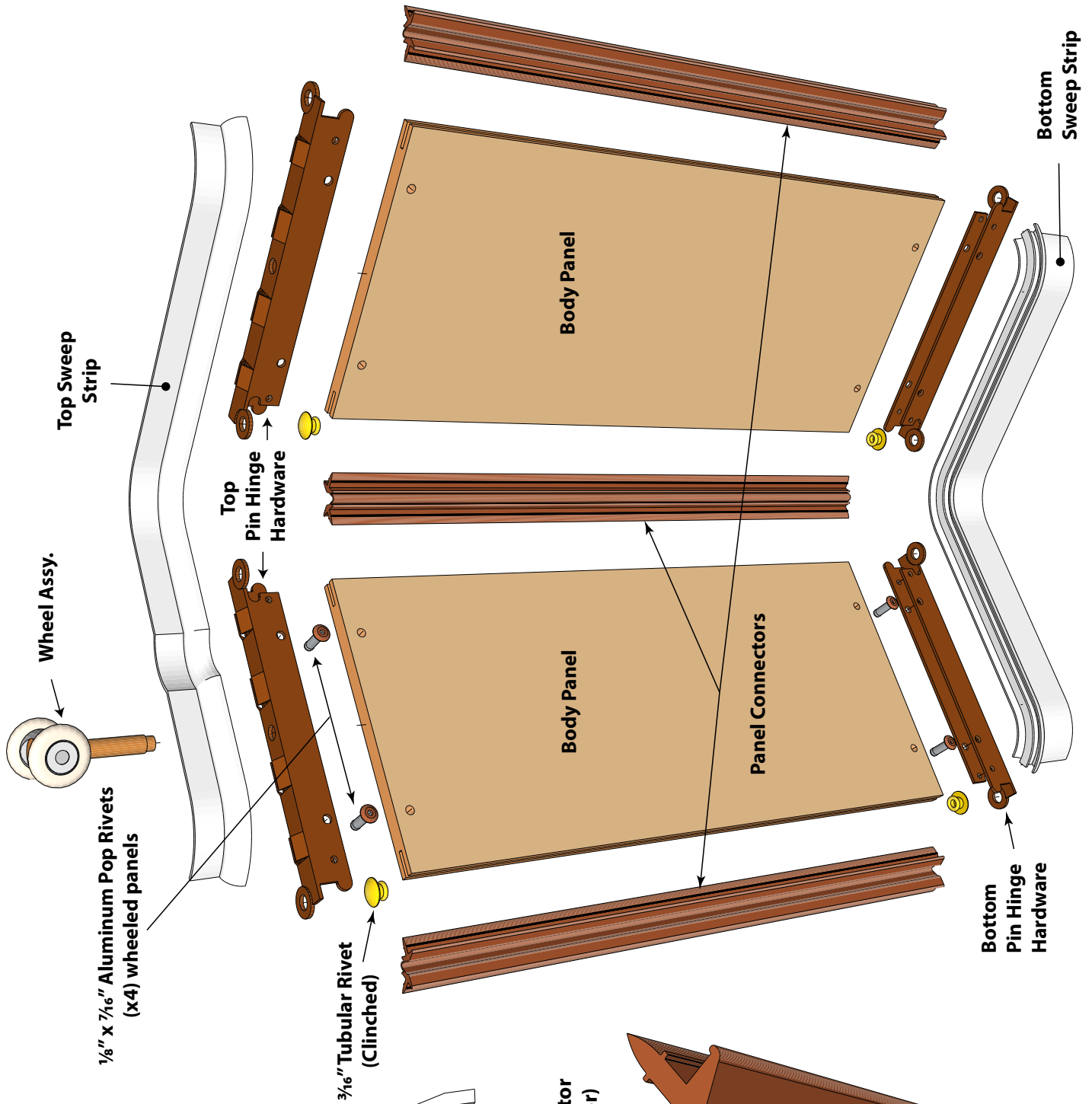

Sweep Strip
Same Top and Bottom except Flange Height

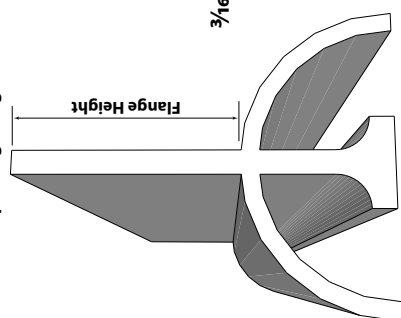

Body Panel Connector (Flexible Connector)

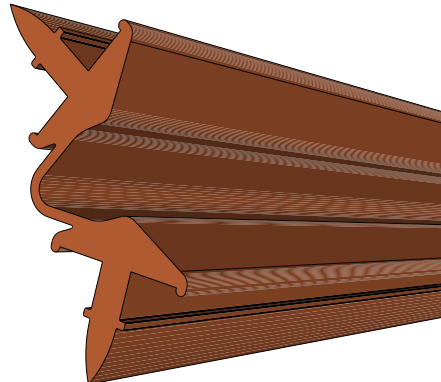

LEAD POST GROUP

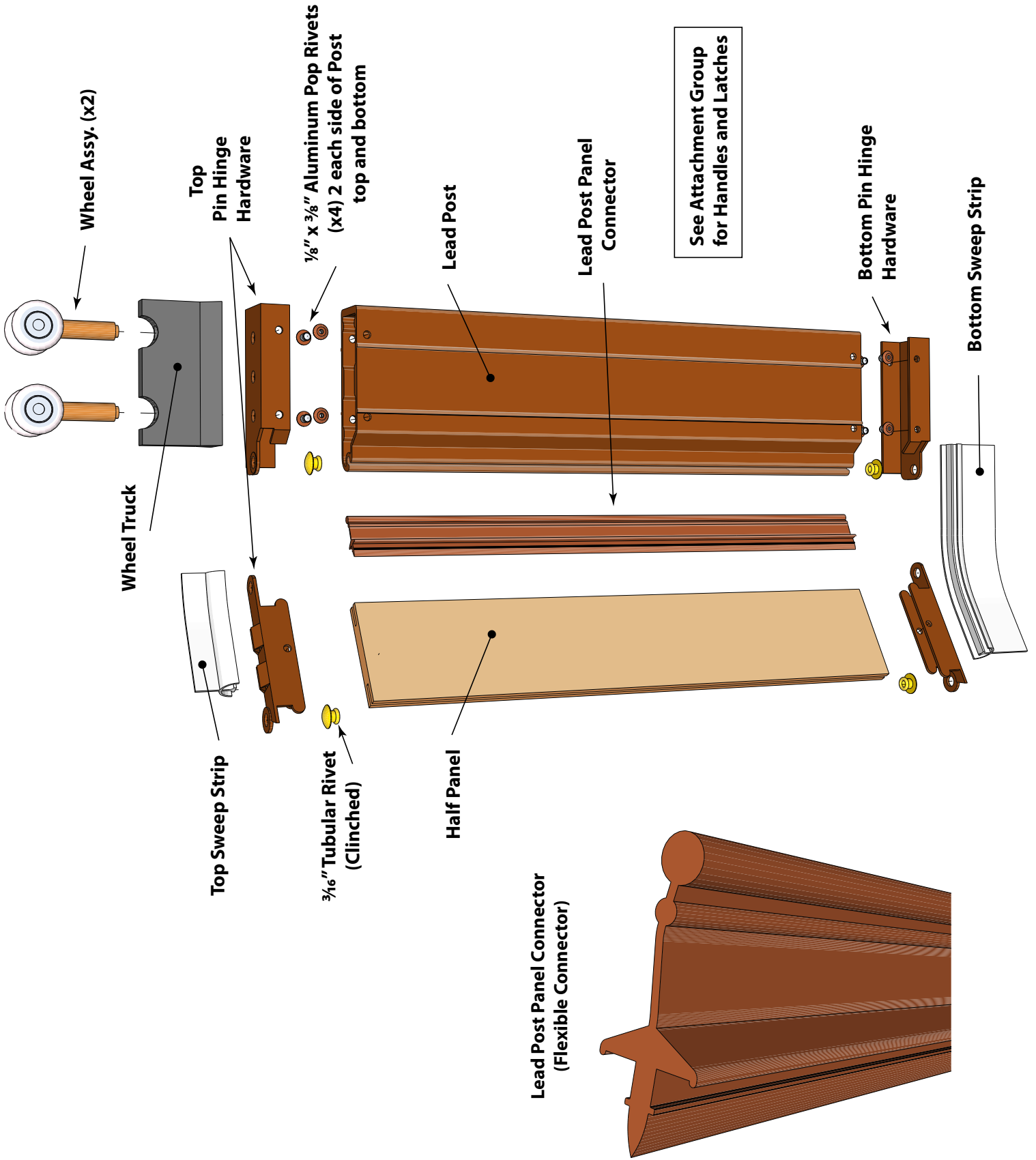

LEAD POST ATTACHMENTS

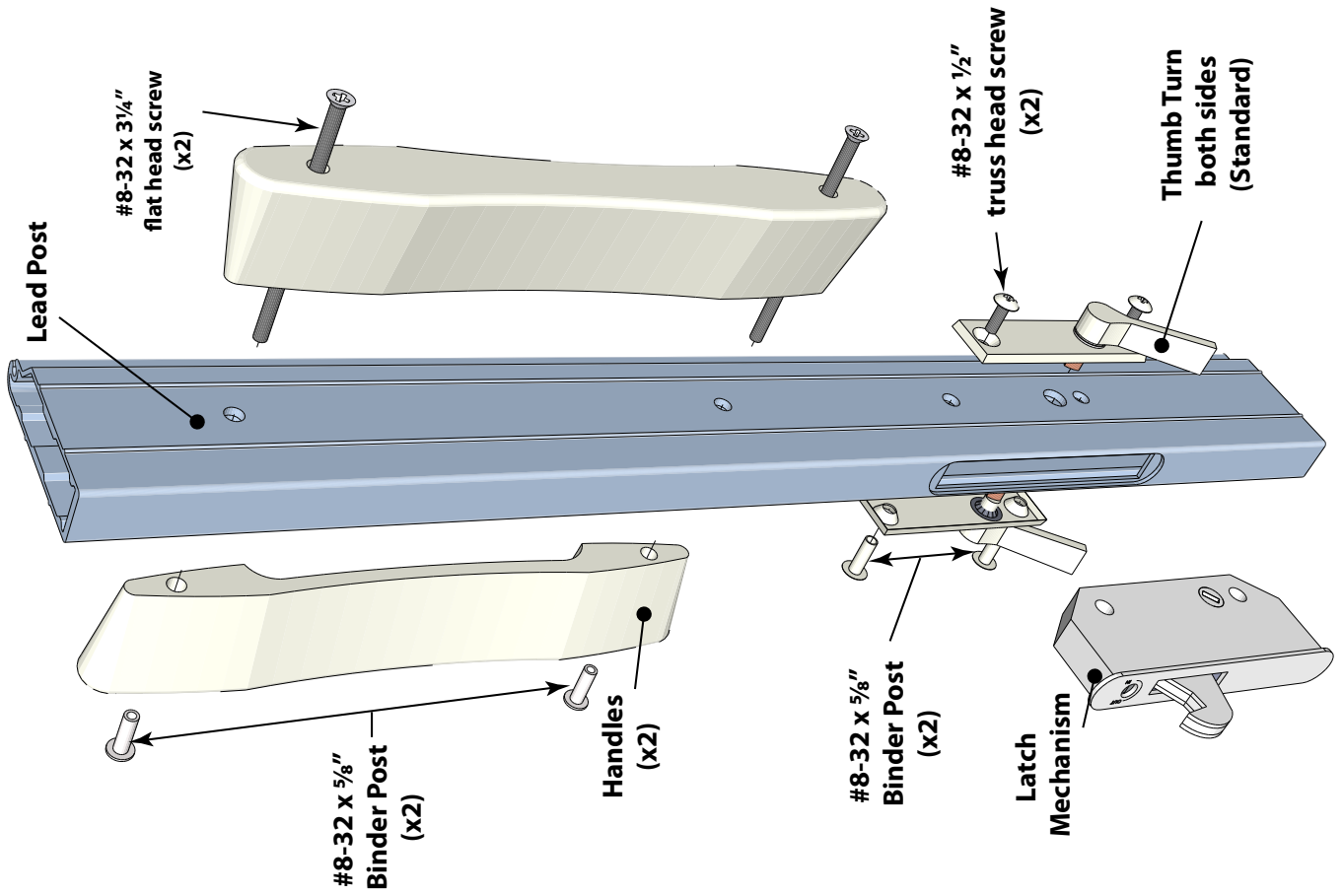

LATCH OPTIONS

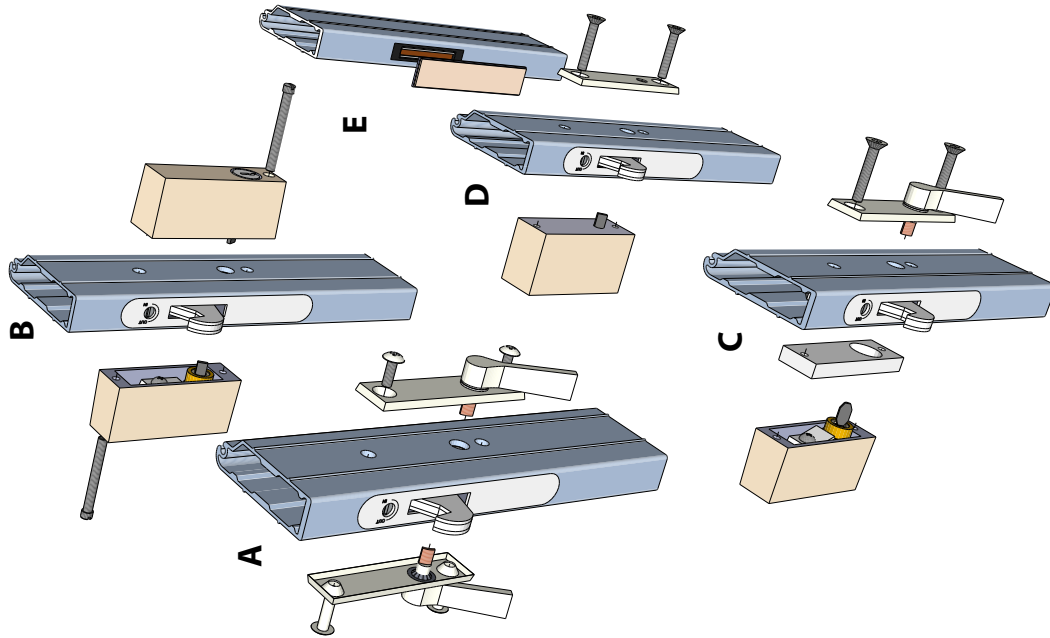

- A. Thumb Turn - both sides (standard)
- B. Key Lock - both sides (option)
- C. Key Lock & Thumb Turn combination (option)
- D. Key Lock & Plate combination (option)
- E. Magnetic Catch & Strike Plate (option)



TRACK AND INTERLOCKING JAMB MOLDING GROUPS

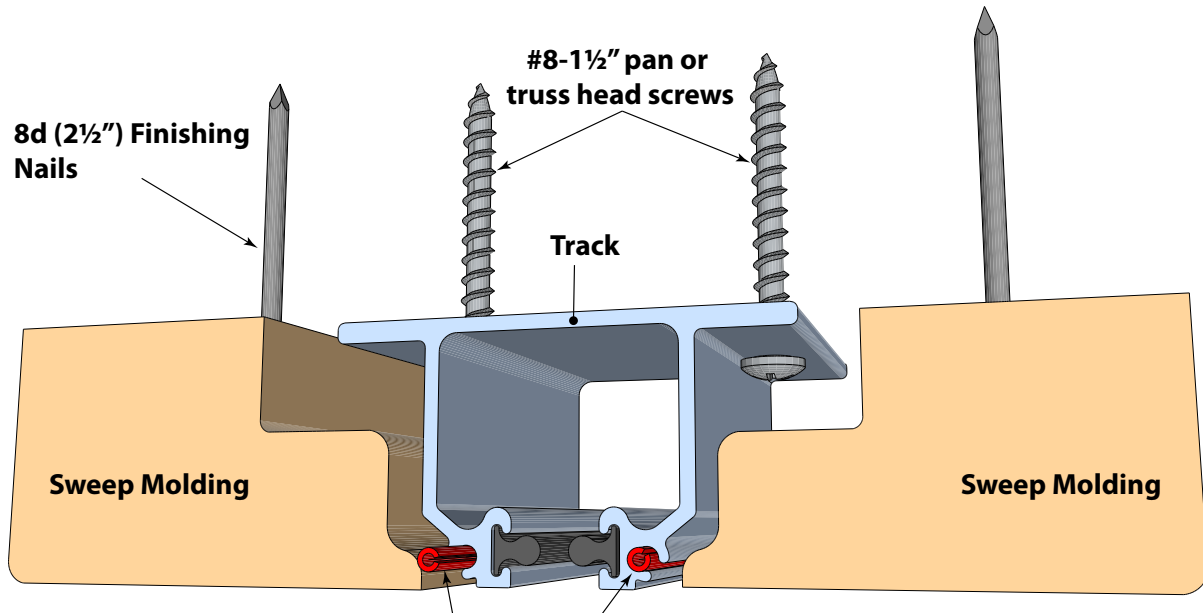

Interlocking Jamb Molding (IJM)

